

Public Comments Submitted to PCAST from December 24, 2009 to March 5, 2010

As specified in the Federal Register Notice, because PCAST operates under the Federal Advisory Committee Act (FACA), all public comments and/or presentations will be treated as public documents and will be made available for public inspection, including being posted on the PCAST Web site.

Dear Dr. Deborah D. Stine and all other members of PCAST:

Here are my written comments to PCAST; thank you for the opportunity to submit them.

I am a U.S. citizen, and I have several substantive comments on PCAST's work topics. None of my comments (below) are for business marketing purposes.

I understand that PCAST is charged with advising the president about national strategies to nurture and sustain a culture of scientific and engineering innovation. Strong innovation requires the sharing of information in a cooperative, open manner. In recent years, this sharing has been hampered by excessive proprietary rights and secrecy. To encourage innovation in science and technology, I recommend the following:

1. Require public access of all research papers developed through government funding. They should be posted on the world-wide-web without charge or registration using open standards (such as PDF or HTML).

NIH is leading the way here (<http://publicaccess.nih.gov/>). "We the people" paid for the research, so "we the people" should receive the results.

2. By default, release as open source software (OSS) all research & development software funded by the U.S. government, unless the government makes a specific determination that it should not do so (e.g., because such release would harm national defense). Consider expanding this to all software developed by U.S. government funding.

Historically, developers gain essentially exclusive rights to software developed using government funds, leading to a hampering of innovation. Since open source software is commercial software, such releases are in fact a commercialization strategy. Red Hat (a vendor that focuses on supporting open source software) just became a member of the S&P 500. The Internet flourished in part because the government paid for the development of open source software implementations of its key protocols. But unlike older commercialization approaches, releasing as open source software lets ALL U.S. citizens enjoy the results of software whose development they paid for. (Indeed, it can be argued that ALL government-funded software should be so released by default.) In short, if "we the people" paid for development of such software, then by default "we the people" should receive it.

3. Eliminate software patents.

For many years, patents were not permitted on software, and software innovation flourished. However, recent rulings and interpretations have in essence permitted patents on software in the U.S., greatly hampering software innovation. Software makers have attempted to innovate in spite of these interpretations, through various cross-licensing deals. Unfortunately, these can hamper small businesses (who are often where innovation flourishes), and the rise of "patent trolls" (who make

nothing and thus do not need cross-licensing deals to make software) is beginning to harm even large organizations. The U.S. Federal Trade Commission (<http://www.ftc.gov/os/2003/10/innovationrpt.pdf>) found that many believe "software and Internet patents are impeding innovation... impairing follow-on incentives, increasing entry barriers, creating uncertainty that harms incentives to invest in innovation, and producing patent thickets". Bessen and Maskin demonstrated that as U.S. software patentability went up, software innovation went down (in contrast with the rest of industry) <<http://www.researchoninnovation.org/patent.pdf>>. For more information, see <<http://endsoftpatents.org/>>.

4. Shorten the copyright duration, and make it opt-in not opt-out.

The U.S. Constitution states that Congress is empowered "To promote the Progress of Science and useful Arts, by securing for limited Times to Authors and Inventors the exclusive Right to their respective Writings and Discoveries". The limit on time is critical; innovators must build on other works, and the effort to gain rights on other works can impede or prevent new innovations. As Thomas Babbington Macaulay stated in a Feb. 5, 1841 speech to the House of Commons, "It is good that authors should be remunerated; and the least exceptionable way of remunerating them is by a monopoly. Yet monopoly is an evil. For the sake of the good we must submit to the evil; but the evil ought not to last a day longer than is necessary for the purpose of securing the good." <http://www.apig.org.uk/index/APIG_DRM_Report-final.pdf>. Unfortunately, there is no longer any balance; copyright durations (originally 14 years with a renewal for 14 years) have been repeatedly extended far beyond what is justified by this clause. What is more, copyright is automatically granted (instead of requiring an affirmative label), making even ordinary actions technically illegal, and making rights-clearing nearly impossible.

Instead, shorten the copyright duration, and only give copyright if a copyright statement is specifically affixed (e.g., an "opt-in" instead of an "opt-out" system). This will enable new innovations to more easily build on previous work. The specific length should be based on a scientific economic study; see this for one such analysis: http://www.rufuspollock.org/economics/papers/optimal_copyright.pdf

I provide these comments as a private citizen; I do not represent my employer (or anyone else). But I believe many others share my concerns and would agree with these recommendations.

Thank you for your time.

--- David A. Wheeler

Gentlemen:

I have been aware of the energy crisis since 1973, when we were in a great turmoil and under the gun. As an American who has spent my entire career working on national security issues, weapon systems developments and other government-related projects, I am frankly appalled at the total lack of interest and activity associated with this energy crisis. Make no mistake about it; we are in an energy crisis that is getting worse every day, and that is affecting this country's national security, as well as its domestic behavior. I have written a white paper attached that addresses this issue and recommends to you a way of tackling its solution. I am willing to discuss this paper and work with you in carrying out the implementation of the plan proposed herein. Thank you for listening.

Frank Blitzer

Frank Blitzer

7627 Albacore Drive

New Port Richey, FL 34655

(727)372-6763

fblitzer@tampabay.rr.com

A Sound Energy Policy: The Key to Energy Survival

By

Frank Blitzer

June 29, 2009

A Sound Energy Policy: The Key to Energy Survival¹

1.0 Introduction

The most significant problem on this earth today is the survival of the human race. Evidence that human survival is in peril is manifest in the actions being taken by people and governments today in various ways: crime is on the rise; wars are in progress all over the world; global catastrophes such as famine and disease have killed thousands of people all around the globe; natural catastrophes such as the tsunami in Asia on 2004 and the earth quake in China in 2007 have killed 100s of thousands of people; HIV/AIDS and Malaria are running rampant in Africa and spreading. These events have been present for many years, but in the past several years the frequency of occurrence of these types of events has been pronounced. This may be due to a number of things; natural environmental cycle on the Earth, pollution of the atmosphere, population growth, people unrest, famine, pestilence, and perhaps other things, I am not familiar with.

This paper cannot possibly address all of these subjects. Rather, it is focused on one of the most important issues of this century, that of energy: energy shortfalls and the power grid problems in the U.S. are becoming acute! In particular, since the oil embargo of 1973, this problem has persisted, particularly the problems with the power grid in the US, the cost of energy and the US oil dependency crisis. Yes, this country has given away its energy resource control, a major strategic resource, to foreign countries over the past 45 years. During the period since the oil embargo in the US in 1973, the United States Government has done little or nothing to relieve the inevitable result of the energy problems that have persisted since the 70s. The power grid in this country has almost reached its limitations. Yes, one can add power plants to the grid, but the added power payoff per unit kw-hour added is almost less per kilowatt-hour than the benefit to the country and the costs that are added in the supply and control of energy are rising significantly. Also, the reliability of the power grid is very poor. A loss of power in one part of the grid is supposed to be supplied by backup energy sources, but even this capability is in jeopardy today, due to the grid's "saturated" condition. Note that the power failure that occurred several years ago in Ohio almost caused a calamity in this country as the short circuit that occurred could not be adequately supplied to the system in a timely manner in response to the demand on the system. To make matters worse, the US is heavily dependant on foreign oil. Seventy percent of our oil is imported from outside sources today. We have given away our major strategic resource. As we have learned from T. Boone Pickens this past year, this country is losing \$700 billion annually to foreign oil.

¹ The fusion information provided in this paper was taken from an Internet article "Nuclear Fusion Power", Internet Address, Nuclear Fusion: WNA, WHTML Document, dated May 2007

This strategic resource needs to be protected, particularly in the event of hostilities, and the probability of this occurring from terrorist threats is increasing tremendously and is becoming a serious global problem. Moreover, this problem is becoming acute from our standpoint and more likely every day, as one can see from the Iraq situation, the Israeli/Gaza conflict, the Afghanistan war and most recently the Georgia situation. The Russians are getting stronger and China is already making a bid for economic supremacy in the world. Their population is dominant in this world particularly and demands the need for food and other resources like fuel. They are even funding our internal problems. The China demand for fuel is one reason why the cost of gasoline has risen far beyond a tolerable level and it is likely that increases in the cost of oil will continue in the future. Finally, fossil fuel resources are unclean and the supply of oil will run out in the next 100-150 years. In short, this energy problem is at a pivotal point in history, requiring that the US government develop a plan and policy to update its energy resource preparations so that its strategic goals can be met. This means that the US must again regain its independence of oil as one of its most important strategic assets.

Today, the price of oil has risen way out of proportion, which is affecting the entire global economy and the US economy in particular. Recently the US economy has almost collapsed reaching the proportions of the Stock Market crash of the thirties, and this is affecting the economies of major countries around the globe. While the energy situation is not the sole basis for this economic condition that the US is experiencing, now, it is a large contributor, because the energy cost fluctuations we have been experiencing creep into every major commodity in the world. The production and delivery costs associated with energy, and movement of products around the world demands a great deal of energy, and, therefore, the contribution these costs are making to the survival of the US are insurmountable unless the US adopts an energy policy to free its dependence on foreign oil and solve the long range energy needs of this country. Congress has been putting its head in the sand since the seventies, and is making political suicide attempts to “band aid” the energy problem, by putting a few research dollars into “alternate fuel source” developments, none of which will influence any serious rectification of this monumental problem, particularly in the near term. This approach may be placating some folks in this country, but is having a lasting impact on the US economy and the global strategic position of the US. This paper concentrates on the issue of the future energy resource requirements that must be addressed if the country is to survive and prosper.

- 1 .Eliminate oil dependency
- 2..Put the economy on a safe responsible footing to supply reliable energy for its growing population
3. Provide a large energy resource for the next 150 years
4. Accommodate the population growth of the country

5. Provide a strategic resource for protection against future crises
6. Help in stabilizing the country's economic stability
7. Regain the US control of its economy and future

The energy sources that are available today offer very little potential for improvement in energy capability on a large scale to accommodate this country's needs in the next 150 years, despite what political candidates are saying. Here are the possible available energy sources, but by no means an exhaustive list.

- Fossil Fuels (Coal, Oil, gas, etc.)
- Wind Energy
- Solar Energy
- Nuclear Fission Energy
- Nuclear Fusion Energy

2.0 The Energy Sources

This section discusses the various possible energy sources, but it does not exhaust the number and types of sources. Instead it focuses on some of the "green" sources that most commonly discussed in the media. There are many other sources that need to be considered. Among these are geo-thermal, shale and others like these two mentioned.

2.1 Coal

Fossil fuels (oil, coal and gas) are in wide use today and require considerable work to increase their life and cleanliness. US oil reserves are dwindling, oil in the ground is available for drilling, coal is plentiful and gas is available in large quantities. Getting to the resources we have has two significant problems, as I see it.

- Drilling for oil and gas is a long term process(10 years)
- Fossil fuels are not Green solutions
- We are short on refineries

Even if these changes can be accomplished they are still "dirty" commodities. Coal is used to supply about 50% of the countries' needs today. It is in abundance, but it is not a clean resource without additional expenditures of funds and time to make it so. Even though such clean fuel sources may be available, coal still cannot supply the amounts of energy that will be required to meet the demands of the US growing population in the next 50 years. Adding coal power plants to the power grid, will not materially add to the energy capability on the power grid, either, because the power grid is woefully incapable of accommodating the growing energy needs of the populace, cost effectively. Furthermore, coal still has the problem that it is not a "totally clean" source of energy and still fuels greenhouse gas

emissions. In summary, increased cost to make it a cleaner source and insufficient energy to take care of the long term rising population, are reaching diminishing returns.

2.2 Oil

Oil is a desirable resource, but the environmentalists in this country are limiting the ability of the US to drill for oil and its refining capabilities need considerable growth in capacity to meet the demands of the next 50 years. Even so, the US oil reserve is dwindling. Therefore, the U.S. is forced to depend upon foreign oil for its needs. This situation is expected, not only to continue, but also, to get worse, and the US will find itself in a strategic cul-de-sac, with no ability to ease its geo-political position in the world, since the competitive demands for oil are increasing, particularly from China, a major third economy. Moreover, the Middle East is having a hay-day making it impossible for the US to achieve its goals, even though our use of Middle East oil is only 30% of the world consumption. The US finds itself in a very vulnerable economic and military(security) position, and the cost of meeting the US energy demands has reached prohibitive proportions(over 700 billion dollars annually)affecting the U.S economic capabilities, too. Moreover, oil supplies are limited to about 150 years, and will take millions of years to replenish, as does coal.

These same arguments apply to gas, though it is in abundance at the present time, because the US has not focused on its use for major energy consumption for automobiles and industrial applications.

2.3 Solar and Wind Energy

Solar and wind energy techniques are limited in how much power per unit energy source can be generated cost effectively. The cost per kilowatt-hour (\$/kw-hour) to develop and deliver production energy to the multi-millions of users in this country is the *key figure of merit* that needs to be assessed. While solar and wind energy sources are relatively easy to obtain, they have limitations as an economical resource capability: it is questionable how much they can contribute large the large energy demand. (greater than 30%) The efficiency of these systems is improving because of technology improvements, but they are insufficient to exploit for large demand and not cost effective for large demand, either. A practicable power source physical size that would supply power of reasonable cost effectiveness produces a power output level of about 50kw. Today's wind power capability seems to range around 5-8 kw-h. Solar energy efficiencies today are only about 11%. Therefore large solar farms are required to meet the demands that are projected in this country in the next ten years. These amounts may be somewhat improved with today's technology, but it is unlikely that a practical capacity for either of these sources of energy could be made available for supplying more than a limited power source to supply a house or small building efficiently within the next ten years, without the need for very large energy farms to supply only small communities. Moreover, the cost to develop these improved capabilities will more than likely require development funds exceeding the recent national debt in these next ten years. And then the transmission facilities for delivering the energy to a community would be excessive in cost for development, production and transmission. Some say that wind energy can supply the entire

country's needs from a source of supply located in the Northern States (N. Dakota, S. Dakota and Minnesota). If a short circuit in the power grid were to occur, when powered in this way, this problem could bring power in the entire US to a standstill, because of such a concentration of power in only a small concentrated area. And what would happen when wind and solar patterns change? Also, what happens to the country's needs when there are power grid catastrophes? Going to large farms for wind or solar energy, has a practicable limit in farm size and \$/kw-hour. Perhaps, since the cost of fuel has reached an unusual dollar size today, those proponents for wind and solar energy believe it is now cost effective to use them. I believe that this approach is just folly, and the jobs it would provide or the money that its owners would charge would become prohibitive and temporary. And I also believe that there is pressure by that sector of the economy to get increased revenue and profits for existing business interests from their companies. This may offer more jobs, temporarily, but I do not believe that it represents a good long-term approach for America that will assure it remains independent. We must seek another, more suitable solution to this problem. I do not believe this is the answer. I believe this is a "band aid" that some eager people think they can make money with by getting the government to foot the bill to put in place a limited or constrained capability. Moreover, what happens when there is no wind and when it is dark or cloudy? Perhaps it can help for short term, back-up solutions, but this is not the long term answer. The literature shows that the payback for a \$3000 solar system for a home is so large that it can never be returned. The cost effectiveness of these resources is highly questionable. Perhaps this type of energy source has merit for small enterprises, but it cannot supplant the US heavy dependence on oil for homes, factories, cars, etc. The total US population and industrial base must be given cost effective energy capability. This is a requirement of the government to make such energy available to all.

2.4 Nuclear Fission

Nuclear fission is the technique that is in use to supply nuclear power today. While very capable of supplying the power cost effectively (less than 5 cents per kw-hour) nuclear fission can meet needed energy demands and sustain growth. And it can very cost effectively handle surges in emergencies, though the problems of waste elimination and reliability are intrinsically difficult, while they have been significantly reduced since the 3-Mile Island disaster. France's power consumption relies 80% on nuclear power. The US only utilizes about 20%. While new technologies are available today to reduce risks in these areas, nuclear fission still poses health problems and other issues. Moreover, the environmentalists have formed a large political lobby that is fighting this technology. We must dispel their fears. So it is not the most desirable energy resource to increase power production using nuclear fission reactors, though this may be a necessity in the near term. Perhaps this type of energy source has merit in some quarters, but it is not a desirable resource for the population at large. Moreover, the handling of waste materials is truly an enigma.

2.5 Costs Versus Energy Source

The energy sources described above each have implications in implementation, cost and performance. But the most tell-tale issue is the cost effectiveness, which is expressed as the cost per Kilowatt-hour. This parameter is a major figure of merit in determining the best solution or the most “cost-effective” solution to choose. By cost-effective, it is meant that the figure of merit can be used to evaluate the cost/benefit of opting for one energy source over another. This figure of merit must be viewed as a function of the application under consideration. This methodology needs to be applied to the energy source requirements for heating, air-conditioning, automobiles and industrial needs, and other like sources of supply in connection with residences and commercial enterprises. The automobile energy source requirements need to be selected on the bases of their requirements for coverage/usage, cost-effectiveness and pollution control issues.

Figure 1: U.S. Electricity Production Costs

More than likely these requirements will differ considerably from the other commercial domains.

Data shows that the efficiency of wind power, which is the ratio of input wind energy-to-output electrical energy hovers around 20%.

Approximate values of cost for each type of energy source are summarized in table 1, along with some of the cost elements that pertain to each source. The direct costs allotted to the Wind energy source do not include the direct costs involved.

Table 1: Summary Costs of Sources in Cents/kw-hr.

Figure 1 presents a summary of cost-effectiveness versus each type of energy source for typical power

<u>Cost Element</u>	<u>Coal</u>	<u>Nuclear</u>	<u>Gas</u>	<u>Solar</u>	<u>Wind</u>
Capital	0.72	0.9	0.42	17.12	2.45
O&M Cost	1.0	1.4	0.50	1.00	1.00
Energy Source	2.5	<p>U.S. Electricity Production Costs 1995-2005 (Averages in 2005 cents per kilowatt-hour)</p> <p>2005 Nuclear 1.25 Coal 2.27 Gas 7.51 Oil 1.09</p>			3.14(Direct Costs)
Other	6.07	0.25	8.09	Not Defined	Not Defined
Total	10.29	3.31	8.09	18.12	3.45

sources for homes and industry needs from 1995-2005. The figure presents curves for nuclear and fossil fuels based upon year-2005 data. The data shows that gas, oil and coal costs are approximately 2.5 times higher than that of nuclear energy. This data is based on production costs only. Before fusion energy can be assessed the development and production costs must be determined. But after the development is completed, it is anticipated that the cost per kw-hr will approach the same level as is being achieved with nuclear fission. However, it is recognized that this analysis should be performed for the particular requirements anticipated for this new energy situation of today.

Table 2 shows cost comparisons for each energy source as a function of some of their cost elements. These costs are based on year-2005 data, also. However capital costs are included showing that it is important to take these costs into account. What are not shown in these two sets of data are development costs for wind and solar and nuclear implementations, plus costs to build and install the power sources and transmission plants for them.

The renewable energy sources must be looked at in view of the new requirements, too. If renewable energy sources are to compete favorably, these sources must have comparable cost per kw-hr comparisons. Also, renewable energy sources may not be applicable for all possible energy uses. In this case their costs need to be adjusted for the anticipated percentage of usage.

Table 2 presents a recent summary of costs associated with energy usage percentages in this country for various energy sources and summarizes the average cost per kw-hr for all sources of energy in use. Note that these costs average a higher cost than is presented in figure 1. This is because the renewable energy sources costs are higher and some of their percentage usages is lower than the major sources in the table. This means that the cost per kw-hour is necessarily higher than the other principal sources of energy, because of the low usage. To step up this usage and get the cost down would take a prohibitive amount of funds. This is not a desirable direction to follow. Transmission of energy in the country is a very expensive process, and the transmission plant needs a major overhaul. Solar and Wind transmission systems are very complex (see figure 3) and their cost to develop and implement will become prohibitive as demand is solved with them. Making renewable energy competitive with nuclear, coal, oil and gas, would impose a significant demand on funding resources. Also, it is questionable whether these energy sources could aid significantly in reducing the country's dependency on oil from other countries in the next ten years. Moreover, it should be stressed that the wind and solar energy sources need much development in order to be able to service large areas in the country to be competitive with those that are currently in use. This is why nuclear fusion should be given greater emphasis as a broad energy source that can service millions of homes, factories and large industrial centers, particularly since capital expenditures would be needed for wind and solar solutions. Nuclear development will ultimately provide

a greater coverage to auto, home and industrial users . These data show the necessity to examine all the major energy sources to determine which combination best satisfies the country’s requirements for energy and costs. Table 2 infers the need to adjust the percentage usage of these sources in a more appropriate manner for today’s needs. This task will require the addition of development costs and production costs to redistribute the power grid arrangements; this requirement will need an expenditure of significant funds.

Table 2: Average Cost per kw-hr

Energy Source	% Usage	Avg. Cost/kw-hour
Coal	52	
Nuclear	19	
Gas & Fuel Oil	18	
Hydroelectric	7	
Wood/Biomass, Wind, Solar	4	
National Avg. Cost		8.83 Cents

(Based upon U.S. Department of Energy, January 12, 2007)

3.0 Nuclear Fusion

Nuclear fusion is the process that we observe taking place on our Sun every day. The Sun burns hydrogen atoms in its core under high heat and high pressure. This fusion process causes the formation of helium atoms. The fusion process continues, next burning the helium to form the third atomic structure, lithium, which burns to form the next complex atom, etc. In this process an extremely high energy output is created that can be used by many homes, factories, cars, trains, etc., if harnessed correctly. This approach can be used by the US and other countries by creating fusion nuclear reactor technology. It is a cleaner resource with more capability to be controlled than fission. The techniques that are being developed are approaching a point of demonstration in the very near term. A program on PBS on March 9th took the listeners to Lawrence Livermore Laboratories to view the developing energy source. Today it takes up a very large facility. We need industry to make the technology practicable.

Work has been on-going at a snail’s pace to develop such a reactor, since 1973 too, but the solution has escaped the physics community for decades, and the government has not developed an energy policy that would incentivize our energy industry to vigorously pursue this science. Research has been ongoing

for the past 50 years or so, but the development of the fusion technology has always escaped its developers. Currently, a consortium of foreign countries have banded together to develop a demonstration reactor with the idea that, if successful, the group would proceed to develop a commercial version of the fusion reactor. The US is a member of this consortium, which is projecting that this development will take the sum of \$121.8 Billion over a period of 50 years. This is a ridiculous schedule. It shows that there are two problems: 1) There is not a team with the expertise to move this technology forward; and 2) Industry is not involved with the Project except at the technology level. This is not a program like the **Manhattan Project** or the **APOLLO Project**. The funding contributions to this problem have been relatively meager. For a problem as large as the scale of the global energy needs today, the amount of investments this consortium has made pales in comparison with the **Manhattan Project** of WWII and the **APOLLO Project** of the sixties. Perhaps its meagerness is the reason why this progress has been so slow to accomplish anything. Perhaps its funding is below that needed threshold that would guarantee the development of the technology. Cutting the schedule could save money and doing the work in the US could avoid tremendous inconsistencies in understanding how to solve this problem. The world heavy dependence on oil had created enough demand that all countries seemed to be satisfied that the Middle East can supply all their needs. I believe that this has hampered the US capabilities to compete in this global economy. And I believe this approach is folly. The US is placing its survival with a people that have no desire to save the US, its economy or anything else.

4.0 A Proposed Approach

Since the problems of 1973, when an oil embargo was imposed on the US by the Arab nations, the US has been a slave to Middle East oil, 33% of its oil coming from that part of the world today. In addition, Canada supplies roughly 60% and Venezuela, about 10%. Thus, this country is captive to the outside world for its energy needs. This has caused the US to adopt a more conciliatory attitude in dealing with these nations on many levels, which is curtailing its ability to maintain the “walk softly, but carry a big stick” approach. The US negotiating position in the Middle East and elsewhere is very limited, preventing it from maintaining a position of power, so necessary for it to conduct its business in an atmosphere of “common interest.” If the US were to become independent of Middle East Oil, its strategic position in the world could be strengthened, and a much needed resource could be retained for US relief from world political demands.

As a result of the oil crisis of 1973, some research has been ongoing in the physics community to develop the fusion science and technology at only a dribble. Many articles were written at that time in trade journals and newspapers, showing what was being developed and the general approaches being considered. At that time the key issues were that the reactor approach and technology must be proven and the technology must be developed to make the reactor a practicable device. In fact in subsequent years the fusion reaction was actually demonstrated, operating for a very short period of time

(microseconds). However, after the embargo was lifted, the government stopped exerting any effort to mature this technology. Recent reports on progress indicate that over the past 50 years, scientists have been continually surprised by the elusiveness of the technology. This slow reaction to focus and solve our energy problem was particularly true after the oil embargo was lifted. Perhaps the reason for this slowdown was caused by lack of funding focus by those who had the knowledge to move the science forward. Apparently, due to pressure from the American oil companies and other local interests, the fusion research was curtailed, while there were technical people who had offered ideas for continued research that would have borne fruit in a few more years after the embargo was lifted. The politics of this energy situation is fierce. This is where I believe the government made a huge mistake. The seventies through nineties was the time for the government to create another **“Manhattan Project”** that could harness the best talent in this country to make the technology happen. As I recall, in the seventies such a program was estimated to cost \$25 Billion over ten years to perfect the solution to the reactor design. This number may have been very optimistic, but it would have been a lot less expensive to develop the technology in the 70s-90s, than it will be today. At this time in 2009 the amount of money required must be at least ten times that amount or \$250 Billion over ten years. This is \$25 Billion per year over ten years, an amount no larger than the **APOLLO** Program would require today, if one were to initiate that program again. Our country’s economic stimulus program today is spending the amount of 3 trillion dollars. Why shouldn’t 250 billion dollars be applied to this energy problem, now? It would put people to work and would contribute greatly to energy independence and improvement to the US economy. Surely this country can afford that amount, with as much as \$20 Billion per month being spent on the Iraq and Afghanistan conflicts. Furthermore, the economic problems in this country are taking trillions of dollars to solve, reaching proportions that are astronomical, because of stupid blunders that have occurred in managing our financial affairs and resources. The energy problem is one of the most significant of these issues that are responsible for the large economic problems we observe. If we can solve the energy problems we have, I’ll bet we can improve the economy significantly. However, because of the problems with nuclear reactors, the public is also concerned, and these problems need to be faced in direct dialogue with the public and industry, showing that they can be managed to be safe.

4.1 Fusion Reactor Technologies

Today, nuclear fusion reactors can be developed to solve this major resource problem in about ten years. It appears² that the technology is here to make it happen. The PBS program on channel 3, Tampa, FL certainly showed that a laser technology approach is being built at Lawrence Livermore National Laboratory and readied for demonstration. Two approaches have been proposed: Magnetic Confinement (MFE); and, Inertial Confinement (ICF).³ Presently these two approaches are being researched, and the ITER (International Thermonuclear Experimental Reactor) is a consortium of countries including the US that have contracted to develop a reactor and put it on line to demonstrate feasibility at a cost of 121.8 billion dollars (this is over the next ten years, however). The first method uses

² Reports are available on the Internet that discuss the fusion programs, technology, etc. One such report is documented at the end of this article.

³ See article title at the end of this paper

strong magnetic fields to trap the hot plasma. The second approach involves compressing a hydrogen pellet by smashing it with strong lasers or particle beams. This plan is extremely slow in proving that the fusion reactor is commercially viable. It needs to be revisited to determine if this protracted schedule can be shortened. The key to updating this schedule is in the cost and the maturity of the technology.

4.2 An Approach Must Be Taken That Addresses the Issues

There are waste disposal problems associated with the fusion reactor but they are much less than are caused by nuclear fission reactors and their half-lives are shorter. Furthermore, the technology is here that can demonstrate this approach, though a practicable working reactor is needed to show that the sustained energy can be managed on a continuous basis. More importantly, today more than one approach is possible. It is only necessary for the government to get organized, put the right talent and funding to work and put the project in the hands of a team of researchers and industrialists. This approach will assure that the technology can be developed and will demonstrate the capability on time and within the dollars required for the program. With industrialists on the team, a more accurate cost analysis can be achieved. The researchers can define the technology shortfalls so that a plan for resolving them can be defined. The cost will more than likely be higher than this estimate indicates, but the schedule can be much shorter and we can be assured that the result will be delivered on time and within budget.

Germany, France, the US and other foreign governments are already investing in the development of nuclear fusion reactor technologies. The US is also contributing an investment in the ITER fusion reactor experiment. At the current rate at which these investments are being made, it will take 50 years to realize a solution to this system problem. The SDI Program costs were running \$5Billion per year in these United States in 1984. This is equivalent to at least \$10 Billion per year today, based upon about a 4% per year inflation rate. The anticipated costs to reach reactor reality are generally projected to top 60-80 Billion dollars over 50 years. This looks like the equivalent of one-twentieth the price of the **APOLLO** Program in today's dollars; by comparison, a pittance. The US could team with its western allies to develop this powerful, clean energy source and provide energy for the entire world, if the investments could be made over 5-years instead of the next 50 years. The U.S. needs to get focused on this energy shortfall reality, and direct sufficient resources toward the development and demonstration of a fusion reactor in the next five years. The way to do this is to determine if the time to develop the science is technology limited or dollar limited. It is not clear from the data I have found that the technology is limited, though.

The plan must look at the existing technologies and the issues they pose. There are two approaches available to use. Each one poses different problems to the developer. In addition, waste, safety and maintenance issues need to be addressed. From considerations of these issues, a technical/Industrial management team should be assembled to study these issues and recommend which of the two

approaches should be chosen to begin development of a fusion reactor. This team should look at other promising approaches too. Sufficient time has lapsed that other technologies may actually be more efficient and cost effective to pursue. The team should assemble to present the results of their deliberations. This meeting should include discussion of the laser technology approach undertaken by Lawrence Livermore National Laboratory. Any other experimentation should be included in this presentation so that a complete assessment of all the possible technologies can be reached. This presentation should be made to a commission of technical, management and government personnel. A plan should be put forth that defines how this team intends to proceed in the development effort. The

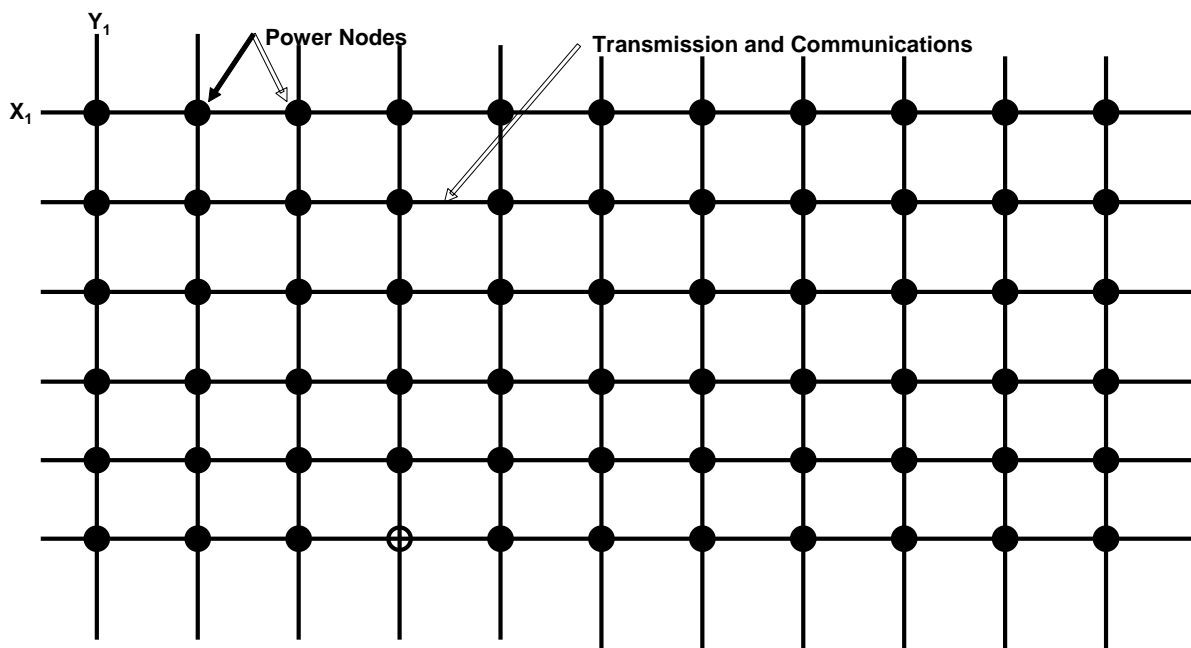

plan needs to set down the following position.

- Detailed assessment of possible technologies
- Description of the chosen approach and risks
- A plan of action and schedule
- Identification of the consortium that will do the work
- An estimate of the cost to perform the development and meet the schedule

The next paragraphs will describe the issues associated with the power grid and recommend the actions that need to be taken to move this program forward.

Figure 2: Power Grid Example

4.3 The Power Grid Issue

The power grid looks approximately like the schematic diagram of figure 2. It is a matrix concept, at which each intersection or node contains power plants that are interconnected through power and communications transmission systems. In general, These power sources may be made up of one or more several types; nuclear, wind, solar, coal, etc. The more sources that are required in a node, the more significant the power transmission system required to accommodate them. The interconnections provide for power transmission and communications capabilities in formatted so that nearest neighbors are activated, as necessary, to route power and communications signals. The power transmission system is the most difficult problem to solve, because it must be used to supply power in a timely manner and it must be reconfigurable to allow backup power from other nodes to serve the users, if there is a problem with the node of concern. Today's power transmission facilities are running out of the capability to handle the future power demands and backup situations. Also automatic backup facilities and grid repair capabilities are sorely in need of upgrade to handle the problems we now have. Therefore, each node, depicted by the large dots, includes one or more power sources with appropriate power transmission, distribution and communications capabilities. At each node the power sources could be combinations of wind, solar, nuclear, etc. power stations. The transmission facilities must be upgraded to handle the power and communications capabilities required of each node's locale. In general this upgrade entails new power transmission lines and integrated nodal designs to allow incorporation of multiple power and reconfiguration capabilities..

4.4 A Look Inside the Node

The node of the power grid is not only running out of power handling capability, but also, the transmission facilities are reaching their limit in carrying capacity, the amount of electric current carrying capacity required to maintain the power and communications to the community it serves. Figure 3 illustrates what the nodal power station must provide. In addition, if more energy sources (power plants) are required to meet the demands on the node, combining the output power of these sources becomes a difficult problem that requires new transmission plant facilities to be design and installed. Figure 3 offers an approach that can be considered, which would increase total capability significantly.

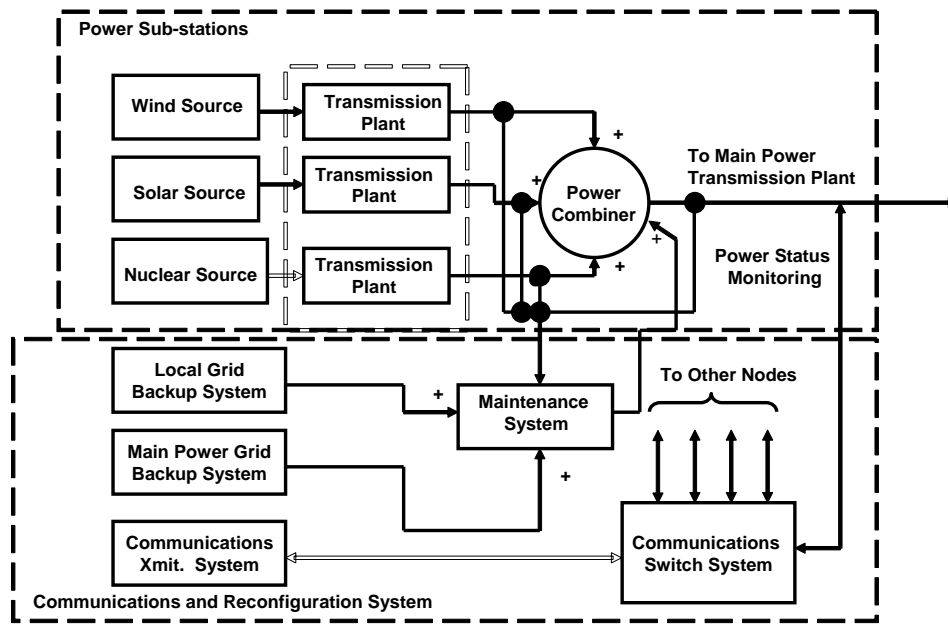

Figure 3: Nodal Power Sub-System

If more than one power source is required, the output power of the several sources would be combined and sent to the transmission plant. Their voltages and currents need to be equalized so that they are compatible, since wind, solar, nuclear and even oil power plants might be installed in a given node.. To be compatible the voltages and currents from these sources must be brought to a common level. This means, for example that each source might be adjusted so that its output voltage and power capabilities would be comparable to those of the other sources. Then they could be combined in the node. To appreciate this problem figure 3 illustrates schematically what is entailed in implementing a typical node. Note that the Power combiner must serve the needs of the node and would be a major overhaul of the node. The communications subsystem monitors the health of the node and also provides reconfiguration capability in the event of breakdown providing backup capabilities in support of node failures. It also communicates with status of its health to all nodes in its vicinity

5.0 Develop an Energy Policy

As one can see this problem is bigger than meets the eye. The nodal power system and the main power transmission facilities need upgrades and major modifications to make them capable of integrating various power sources particularly in large numbers. The nodes need to have a “smart” design to anticipate failures and provide reconfiguration so that power transmission can be successful without interruption. Wind and solar energy, for example, require farms of wind turbines and solar systems to achieve the power levels demanded of their service. The government needs to develop an energy policy that will assure that it has set proper goals for the next 50 years and can reach independence from foreign oil within ten years. The Internet database shows that nuclear fusion costs compare most favorably with those of coal, oil, wind and solar sources. To accomplish this goal of energy independence, the U.S. needs a plan that shows it can/will develop (in the next five years) certain specific energy sources/capabilities that would come on line in five years to allow the US to begin the process of retiring, through normal attrition, existing power plants and transmission facilities on the power grid, replacing them with new systems that permit ready transition in the ten-year cycle to cover increased demands and capabilities giving it time to develop the fusion reactor source over the next ten years. Here is a suggested approach to the plan.

5.1 Proposed Energy Plan

An example energy plan is presented in figure 4. This plan considers four major efforts:

1. A development and implementation plan for interim technology solutions to supplant energy needs in the near term (5 years)
2. A Fusion Reactor Energy plan that includes development and demonstration of the commercial technology, the design, development, manufacture and deployment of the first reactor, followed by production and implementation of production units for installation into the power grid.(5 years)
3. A plan to develop and modernize the US Power Grid and transmission facilities(5-10 years)

4. A plan describing the contributors to the program, their responsibilities and their credentials. If a consortium is selected, a description of the industrialists/countries involved, their contributions and how they will be funded

It should be noted that the power grid of today's design shown in figure 2 may not be able to accommodate the fusion reactor, though the fission reactor is being used in the current system. Also, if alternate energy sources are to be incorporated the current power grid will most likely need to be revised with new transmission plant and smart backup(see figure 3) and maintenance capabilities to accommodate these energy needs. This may require additional effort to incorporate the fusion reactor and other sub-system and transmission plant designs into the power grid. For example, the power networking facility in the node will need to be upgraded to accommodate the various power sources in the node, for reconfiguration and backup of the node in case of failure. It is anticipated that the government may consider creating a consortium of countries to perform this effort of developing and demonstrating the fusion reactor. The ITER Program mentioned above is positioned to do that, now, but I believe that the program can be fore-shortened. This may entail that the U.S. consider another consortium for this purpose or modify this program, accordingly.

The power grid examples shown in figures 2 and 3 may not be quite as accurate as I would like it to be, but it is representative of the one we have in the US at the present time. This is a two-dimensional grid in which the power stations and nodal sub-systems are located at the intersections of the X -and Y- axes on the grid(I have noted the X- and Y- directions on the upper left corner of the grid. These axes are numbered so that each power station node can be identified. The dots represent the power station nodes. Each node comprises the architecture of the power sub-system in that node, which may have several energy sources. Each node may be configured with combinations of nuclear, wind, solar, etc. power sub-stations, etc. Figure 3 illustrates a typical concept. But they must be compatible substations to meet the nodal requirements.

According to the plan shown in the chart of figure 4, a two-step approach is to propose an energy plan that has been designed so that it contains two concurrent initiatives. The first initiative takes place over the first five years, essentially, examining the possible options for near-term solutions to provide an interim energy capability that would last for about 15 years, providing sufficient time for the development and installation of the commercial fusion production reactors into the grid. The first phase should also provide the capability to allow the grid to transition to the fusion power reactors, when they are in production during the second five year period. In this first phase of the plan, the government would create a competitive environment whereby industrial companies would be allowed to bid for contracts to develop and demonstrate one or more of the techniques suggested in the first initiative of

the plan. There may be more techniques, too, but this plan only shows a few to demonstrate the proposed idea. Obviously the near term approach should be some combination of coal, oil, wind, nuclear etc.; versions that would take advantage of these technologies because of the abundance and availability of these items and because many home heating systems already have this capability. Wind, solar energy and other techniques need to be demonstrated in terms of how they can best be utilized and a determination made to show that there are practicable, cost effective solutions that can be employed in communities, cars, etc All of these approaches require analyses that prove the practicality of the energy concept(s) in the home and in the communities in the countries in which they would be used. This plan assumes that a concerted effort, with proper funding can achieve a point in three years where one or more choices can be made for the interim solution to the immediate problem (it will take three years to find solutions, but this does not satisfy the immediate needs of the US. Some additional government support is required in the next three years to help solve the current energy crisis and economy issues).

The concurrent second phase of this plan, developing the fusion reactor, which is actually implemented in parallel (concurrent) with the first, but not related to it, must be initiated at the same time as the first phase in order to assure that it delivers its results in time to provide a fusion system in ten years. It appears that this can be done since the technologies involved have been shown to work, requiring no technical breakthroughs. If this is done, and, barring any significant problems that might arise, like a technology shortfall, for example, it will be possible to demonstrate the fusion technology by developing and building a test reactor, demonstrating the ability to sustain fusion and providing a practical working and potentially economical solution that can go into production. Figure 4 also infers that production could ensue immediately upon successful conclusion of the development phase.

The transmission plant and back-up system designs will need to be designed and developed in the ten years allotted to this plan, too.

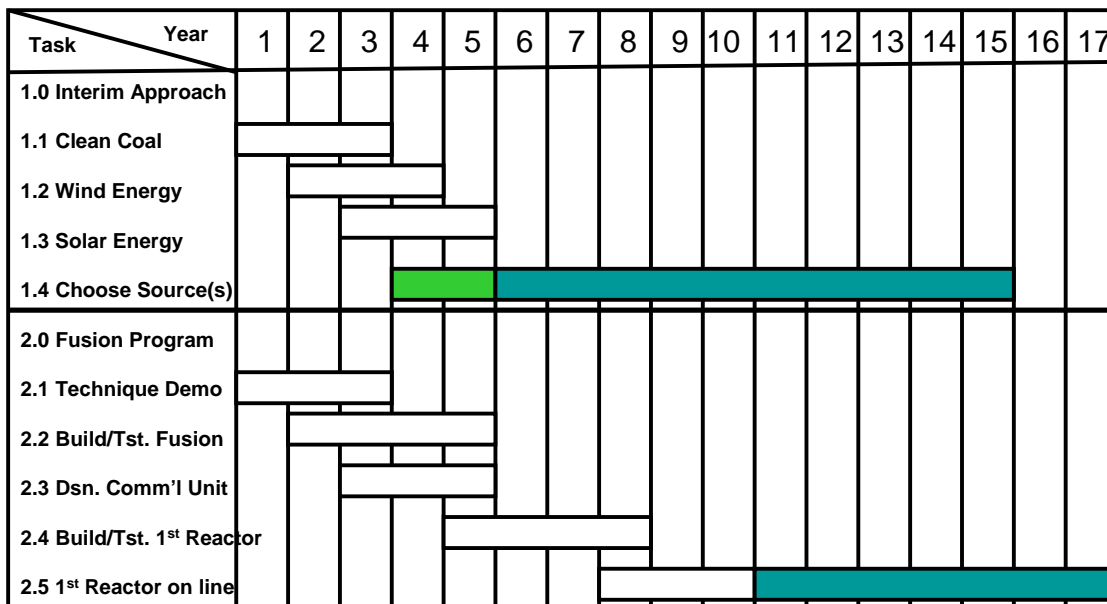

Figure 4: Two-Phase Energy Plan

5.2 Potential Problems

There are many problems that could arise with this foreshortened schedule. There could be technology problems along the way inhibiting demonstration of the reactor technology. Costs could rise due to delays, and other world problems, like the one we are faced with now, that would make the project difficult to complete. The administration changes during this period could affect the ability to complete the project, and our relationships with our consortium members could affect the availability of funding over the ten years. Ideally, it would be desirable to fully develop this program from within the US, because one cannot control the outcome or the schedule in such a consortium as this. Any delays in funding and/or deliveries of materials by the consortium members can affect the cost and schedule of Figure 4.

5.3 Action Items

It is recommended that the congress take the action to assemble a panel of technical, government and industrial people who have the credentials to create a conference of informed people from all camps. This audience would meet to formulate the detailed plan suggested in this paper. The plan would address the development of the program, including the technical expectations, a schedule and projected costs for such a program. The projected costs need to include the competitive bidding costs, etc. and develop a total cost estimate for the program, a program that would be organized much like the **Manhattan Project**, the **APOLLO Program** and the **SDI Program**.

6.0 Conclusions

The use of fusion power plants could readily supply the energy needs of America's domestic and industrial demands and substantially reduce the environmental impacts of increasing US energy demands since, like nuclear fission power, they would not contribute to acid rain or the greenhouse effect. Fusion power, if feasible, could easily satisfy the energy needs associated with continued economic growth, given the ready availability of fuels. There would be no danger of a runaway fusion reaction as this is intrinsically impossible and any malfunction would result in a rapid shutdown of the plant. There is the nuclear waste problem to contend with. This problem must be looked at very thoroughly to assure the public that it can be controlled and is less of a burden than that developed by the fission reactor. Generally, nuclear fusion should be clean and reliable.

Although fusion generates no radioactive fission products or transuranic elements and the unburned gasses can be treated on site, there would be a short-term radioactive waste problem due to activation products. Some component materials will become radioactive during the lifetime of a reactor, due to bombardment with high-energy neutrons, and will eventually become radioactive waste. The volume of such waste would be similar to that due to activation products from a fission reactor. The radiotoxicity of these wastes would be relatively short-lived compared with the actinides (long-lived alpha-emitting transuranic isotopes) from a fission reactor.

There are also other concerns, principally regarding the possible release of tritium into the environment, if this technique is used. It is radioactive and very difficult to contain since it can penetrate concrete, rubber and some grades of steel. As an isotope of hydrogen, it is easily incorporated into water, making the water itself weakly radioactive. With a half-life of 12.4 years, tritium remains a threat to health for about 125 years after it is created, as a gas or in water. It can be inhaled, absorbed through the skin or ingested. Inhaled tritium spreads throughout the soft tissues and tritiated water mixes quickly with all the water in the body. Each fusion reactor could release significant quantities of tritium during operation through routine leaks, assuming the best containment systems. An accident could release even more. This is one reason why long-term hopes are for the deuterium-deuterium fusion process, dispensing with tritium.

While fusion power clearly has much to offer when the technology is fully developed, the problems associated with it also need to be addressed if it is to become a widely used future energy source. Much will change before fusion power is commercialized, including the development of new materials.

At the current rate of development, fusion power appears to be over the horizon. However, I believe that the schedule can be materially shortened by creating an energy policy that fosters a program like the **Manhattan Project**, which can focus our excellent technical and industrial talents on the problem and by putting enough money on the problem to solve it. The kinds of funds we are talking about are in the realm of the amounts that have been invested in projects like the **Manhattan project**, **APOLLO** and **SDI**. These kinds of funds are much less than that expended during the Iraq War. We need a dialogue on this subject among people in congress, industry and the technical community to raise the interest of the public, on what fusion has to offer the US and the world. Moreover, we need to assemble a conference of key technical, government and industrial people to address the entire subject of energy soon so that we can develop a plan to tackle this most important national problem.

2010 February 27

Deborah D. Stine, PhD Executive Director PCAST

Does PCAST have a policy on changing to metric SI units?
Where can I read such policy?

The use of inch-pound units in the US costs some \$1000 billion per year.
It is time to

STOP TEACHING INCH-POUND UNITS.

I hope you can help with this matter.

Thanks.

Robert H Bushnell PhD PE

Dr. Stine

Dr. Maxon

Verizon is interested in making a submission of two page written comments to the PCAST in advance of the March 12, 2010 meeting

Logistically, how should we proceed today to meet the deadline?

Can we submit them via email and/or do we need to send them via hand delivery? If via hand delivery, please advise to whom and to what address should they be sent.

Thank you.

Best Regards,

David A. Hill

VP & Associate General Counsel - Federal Advocacy

Verizon

(703) 351-3011 (phone)

(703) 351-3655 (fax)

(301) 717-0576 (cell)

david.a.hill@verizon.com

TO: Jim Kohlenberger
Director
Office of Science and Technology Policy

FROM: Verizon

SUBJECT: Topic for PCAST Discussion

The President said in his State of the Union Speech that “the true engine of job creation in this country will always be America's businesses.” Job growth comes from investment by businesses and the record of investment and growth in the broadband industry – wireline and wireless – is remarkable. Not only have billions been invested, but we’ve gone from only a few million broadband connected homes in 2000 to some 70 million today and from 2G mobile networks in 2002 to the beginning of construction this year of 4G networks with speeds that surpass DSL and even cable services in many areas. While the industry is going through stresses as a result of the recession, it still remains competitive, healthy and is the source of substantial private sector investment.

As you know, policy discussions are now going on related to how key aspects of the Internet – broadband access networks – are regulated. In our view, these discussions are vital because they relate to the future growth, innovation and openness of the Internet.

We believe that the Internet’s strength is founded on its key characteristics including self-governance, collaboration, competition, innovation and flexibility. Much of the innovation that characterizes the Internet comes from the ability of Internet players – companies as well as individual consumers – to try new approaches in technology, business models and applications/services. The current policies that are in place have encouraged competition and innovation at all levels of the Internet from the device makers to the applications and content providers to broadband network providers. In particular, these policies have resulted in:

- The investment by broadband network providers of between \$60 and \$70 billion annually for the last several years.

- The deployment of more fiber into local networks and into homes in this country than in all of the EU.
- The rapid advancement and upgrading of mobile broadband networks in the U. S. and the uptake of mobile broadband services by large segments of society, including importantly minority groups who have historically not been connected at the levels of other groups such as white Americans.
- Significant multiplier effects that have created jobs in a range of industries that use broadband networks for their services, build broadband network or consumer equipment, or installing broadband networks and infrastructure.

Verizon alone has invested nearly \$23 billion to build its fiber-to-the-premises network which now passes 15.4 million homes and businesses. Today, Verizon's FiOS Internet service offers download speeds of up to 50 Mbps (megabits per second) and upload speeds of up to 35 Mbps, and it is capable of providing 100 Mbps and beyond. Verizon is currently building its all-fiber-optic network using gigabit passive optical network (GPON) technology, the second generation of optical networking equipment, and we are proud to have been the first in the world to test a 10 gigabit per second feed to a FiOS home last fall.

The Office of Science and Technology Policy has an important leadership role in helping shape the Administration's policy positions regarding the Internet and you have a powerful resource at your disposal to provide sound policy advice – the President's Council of Advisors on Science and Technology. Beginning in the mid-1990's, the PITAC (the precursor to the PCAST) did substantial work to promote the openness of the Internet, investment in broadband networks, and the use of broadband to promote education, health care and scientific research. That work has continued under the PCAST. Given that history, the PCAST has the needed background and experience to provide critical guidance to help assess the policy framework for the Internet of the 21st century.

Americans have enjoyed the benefits of the Internet in large part due to policies followed by Democratic and Republican Administrations for years and continued up through today. We believe in openness and the evidence has demonstrated that competition, innovation and investment have thrived in the Internet ecosystem in part because of these policies. But it is an ecosystem and policy needs to be considered in that light. This is one reason why Verizon and Google worked together to try and find areas of commonality regarding Internet policy and the comments we filed at the FCC reflect what we view as a start at a forward thinking, self-governance model that builds in important transparency and accountability mechanisms. We would like to brief the members of the PCAST about this policy framework because we believe

the ideas are a significant aspect of the important technology work that the PCAST is undertaking.

We look forward to scheduling some time where we could meet to brief the PCAST on this important matter.

Dear Dr. Stine:

As part of the House Science and Technology Committee's preparation for reauthorization of the America COMPETES Act, committee staff recently solicited comments from the science community about the role of K12 science education in the federal science agencies. Because PCAST is reviewing the nation's science education programs to make recommendations to the President, I want to share the comments that the American Institute of Biological Sciences (AIBS) provided to the Science and Technology Committee. Our comments include a number of recommendations that PCAST members might find interesting.

I hope these comments will be helpful to the members and staff of PCAST as you advise the President on science education provisions that may be in the America COMPETES Act and in the reauthorization of the Elementary and Secondary Education Act.

Please let me know if you have any difficulty accessing the attached file or if we may be of any assistance to you on this or other matters.

Sincerely,

Robert Gropp, Ph.D.
Director of Public Policy
American Institute of Biological Sciences

January 28, 2010

Ms. Bess Caughran

Committee on Science and Technology

U.S. House of Representatives

Washington, DC 20515

Via e-mail: Bess.Caughran@mail.house.gov

Dear Ms Caughran:

Thank you for soliciting input about potential science, technology, engineering and mathematics (STEM) education provisions in the reauthorization of the America COMPETES Act.

The questions posed by the Committee in the "Survey on K-12 STEM Education" are extensive and suggest a real interest in maximizing the impact and effectiveness of federal investments in STEM education. A wise federal investment in STEM education has rarely been more important than it is today, as our nation works to reignite the spirit of innovation that offers the promise of solving society's most challenging problems. Given the current economic climate, it is prudent to ensure that federal investments can be used to leverage private funds and other government resources.

It is the case, appropriately, that federal science agencies make some investment in science education. Many federal agencies allocate some resources to the recruitment and training of the future STEM workforce. Various federal programs also support the development of K-12 classroom materials and pre-service or in-service training that help teachers translate for students the results of federal investments in scientific research. Often, it is through these exciting snapshots of science that students learn how scientists work or begin to consider a career in a STEM field.

It is important to keep in mind, however, that these educational materials and programs are an outgrowth of research supported by federal agencies. As the Committee is aware, it is difficult to know how much a science agency should invest in K-12 education programs, especially when there are limited resources available for research.

The National Science Foundation (NSF), for example, makes grants in support of fundamental research in all fields of science. This unique mission of funding all fields of basic science and science education is unique and presents opportunities for cross-disciplinary discovery that are less likely to occur without NSF research funding. Thus, it is arguably the case that NSF should be restrained in its investment in K-12 education programs. It might be that the best investment for NSF K-12 education resources is support of centers for innovative and pedagogically appropriate curriculum development. These centers could address the needs of the K-12 system as well as the needs of the university science education system. For instance, these centers could provide training and resources for current and future faculty who teach introductory science courses, modeling STEM teaching for future educators by illustrating the way STEM is practiced. These centers should be jointly funded with the Department of Education and/or other federal science agencies. Through these strategic investments, NSF could support the development of classroom materials and teachers while remaining true to its unique mission of funding fundamental research in all areas of science.

New federal models for support of K-12 science education materials development may offer a productive method for developing science educators with the skills and resources needed to teach students about the nature of science; rather than simply training students to memorize facts.

Consider the federal investment in educational materials and resources about bioenergy, or some other issue which falls within the jurisdiction of multiple federal agencies. It is conceivable that several federal agencies are funding initiatives to develop these resources. In some cases, the intent may be to provide resources to K-12 educators. These materials might best be developed through a collaborative effort between the Department of Energy, US Department of Agriculture, Environmental Protection Agency, Department of the Interior, and the National Science Foundation. The Department of Education might be charged with coordinating this kind of effort, as it offers, among other things, access to experts in curriculum development, state-of-the-art instructional models, and mechanisms to deliver new programs to educators through state and local education authorities.

In addition to reviewing the role of science agencies in K-12 STEM education, the Committee should ensure that science agencies are properly positioned to help support the needs of college and university science educators. As a growing list of reports chronicle, there is a need to reinvent how we teach science – not only to K-12 students, but also to undergraduate students. It is important to keep in mind that many of today's undergraduate students will become teachers. In July 2009, NSF and the American Association for the Advancement of Science (AAAS) convened a conference entitled *Vision and Change in Undergraduate Biology Education: A View for the 21st Century*. At this meeting, various science education stakeholders identified key goals that could drive reform of undergraduate biology education. These included exposing all students to authentic research experiences, with real scientific methods, data, and tools. Such an approach has been shown to increase student understanding of and interest in science (Seymour et al, 2004, *Science Education* 88:493–534; Lopatto, 2007, *CBE-Life Sciences Education* 6:297-306). Because science agencies have established relationships with scientists, this is the kind of effort that federal science programs can effectively support. These efforts would produce greater results if coordinated and linked to teacher preparation programs. Science agencies should collaborate with the Department of Education, scientific and professional societies, and other appropriate organizations toward this and other goals articulated during the Vision and Change conference.

Biology majors expect to be prepared for the science careers of the 21st century. For this to happen, new educational models must be implemented. Teaching the way we did 100 years ago (AIBS, 1444 I Street, NW, Suite 200, Washington, DC, 20005, p. 202-628-1500, f. 202-628-1509, www.aibs.org) no longer meets the needs of students, scientists, or society. To be scientifically literate members of society or future scientists, students must learn by engaging with real-world problems in an interdisciplinary manner. A recent report from the National Academies entitled “A New Biology for the 21st Century” describes the societal value of this integrated and interdisciplinary approach and states that: “Development and implementation of genuinely interdisciplinary undergraduate courses and curricula will both prepare students for careers as New Biology researchers and educate a new generation of science teachers well versed in New Biology approaches.”

A strategic and wise investment of federal resources must be informed by a thoughtful and deliberate process. The Committee should consider including in the reauthorization of the America COMPETES Act a requirement that the President, through the Office of Science and Technology Policy, President's Committee of Advisors on Science and Technology, and the Domestic Policy Council, conduct a government-wide review of federal investments in STEM

education. These offices would convene appropriate officials from federal agencies to review current programs and practices, identify opportunities for interagency collaboration, and assess future needs and opportunities. Moreover, Congress could direct the White House to include in this review an appropriate array of non-governmental stakeholders. This effort could provide answers to the questions included in the Committee's Survey on K-12 STEM Education. As with other Congressionally-directed activities, the Administration could report to Congress on a regular basis with recommendations for a coordinated federal investment in K-12 STEM education.

Thank you for the opportunity to provide input to the Committee. If the American Institute of Biological Sciences (AIBS) can be of assistance to you on this or any other matter, please do not hesitate to contact AIBS director of public policy Dr. Robert Gropp at 202-628-1500 x 250.

Sincerely,

Richard T. O'Grady, Ph.D.

Executive Director

Ms. Glessner:

Thank you for taking the time to address the questions relating to the Affordable Legal Help company. The Santa Clarita Valley Sheriff's Station has had similar complaints about this company in the past, and have completed an investigation into their business practices. During the course of this investigation, we were unable to determine any criminal activity. Although there may be issues or complaints of bad business practices, those are not matters in which a law enforcement agency could investigate or regulate.

In such cases where there are contractual agreements between various parties, and there is no determination of criminal activity from an investigation, the only recommended recourse that we can offer is to suggest that you consult an attorney for possible civil remedy.

I apologize if this answer does not meet what you are hoping to hear from the Los Angeles County Sheriff's Department and the can sense the frustration you have in dealing with this company. In such civil cases, our involvement is not available and the Court system is the best process to obtain the results which you are hoping to resolve this matter.

A.J. Rotella

Sergeant

Business Relations Unit

Santa Clarita Valley Sheriff's Station

23740 Magic Mountain Parkway

Santa Clarita, CA 91355

ajrotell@lasd.org

"Most people resist change, yet it's the only thing that brings about progress."

From: Erin Glessner [mailto:glessnere@hotmail.com]

Sent: Wednesday, February 17, 2010 9:39 AM

To: feedback@calbar.ca.gov; msc@calbar.ca.gov; billing@calbar.ca.gov; barcomm@calbar.ca.gov; lap@calbar.ca.gov; legalspec@calbar.ca.gov; ptls@calbar.ca.gov; llp@calbar.ca.gov; prohac@calbar.ca.gov; mcle@calbar.ca.gov; providers@calbar.ca.gov; cbj@calbar.ca.gov; pamphlets@calbar.ca.gov; spam@uce.gov; dca@dca.lacounty.gov; secretary.bowen@sos.ca.gov; luvthesun7@hotmail.com; jjackson5434@yahoo.com; calgold@calepa.ca.gov; webmaster@sen.ca.gov; heidi.schwab-wilhelmi@calbar.ca.gov; equalaccess@jud.ca.gov; info@hcrc.ca.gov; dstine@ostp.eop.gov; intern_application@whitehouse.gov; internships@ceq.eop.gov; nstc@ostp.gov; mmaxon@ostp.eop.gov; dcscholar_info@whitehouse.gov; haitijic@usaid.gov; ceainternships@cea.eop.gov; e-foia@ceq.eop.gov; pidb@nara.gov; today@nbcuni.com; nightly@nbc.com; dateline@nbcuni.com; rachel@msnbc.com; countdown@msnbc.com; hardball@msnbc.com; ed.msnbc@nbcuni.com; contact@lapdonline.org; webmaster@lapdonline.org; chamberdirector@loslunasnm.gov; cgarcia@news-bulletin.com; info@lacounty.gov; Dunkle, Michael W.; Shaffer, Ronald T.; Creason, Patricia A.; Low, Stephen B.; rccohen@lasd.org; Cambra, Brenda P.; Lewison, Gregg E; Ibaylis@lasd.org; Rissler, Patrick A; Rotella, Anthony J.

Subject: Affordable Legal Help Scam

I am contacting you to inform you of a Company that needs to be investigated. It's called Affordable Legal Help. This company has been scamming people and not providing any services. I invested \$1500 into this company and received no business. They are advertising that they will help parents with custody problems, with fast results. This is not the case, in fact they don't provide any service but ignoring the client they just hired. I contacted the Better Business Bough and seen that there are several other cases regarding the same situation. Still with no refund or no remorse for their accusations. This company is false advertising and destroying people's lives.

I hired this Company in December 2, 2009. I had my trial on December 22. I was promised 5 interviews with an Attorney, with appointments never meet. Between the 2nd and the 22nd I placed many phone calls concerning the appointments missed by the company and when am I going to build a case. The phone calls and e-mails were never returned. On December 18th I got new representation due to the inconsistency of this Company and requested a refund. As soon as I requested a refund they finally contacted me. After all the problems that I had the past 16 days I did not want to trust this company. They told me that they had my case made up already and that they couldn't give me the full refund. I requested documents to prove that they did indeed work on it and they didn't send me any material. After that they had promised me a full refund and to this day I have not received the money. I have tried several times to contact this company and all I am getting is the "run around". This same situation has happened to several other low class citizens according to the BBB.

Could you please investigate this company? It looks like the BBB is tied up due to all the other complaints toward this company are not completed.

This is their website: <http://affordablelegalhelp.org>

This is what I found on Better Business:

<http://www.la.bbb.org/Business-Report/Affordable-Legal-Help-100088889>

More Complaints:

<http://www.complaintsboard.com/?search=Affordable%20legal%20help&sort=date&everything=everything&page=1>

Contact Information:

Affordable Legal Help, Inc.

25379 Wayne Mills Place, Suite 250

Valencia, CA 91355

1-866-872-9317

Edward Maddison: 661-253-0400 -or- 661-287-9152

Kenneth:661-287-3746

This has been going on for too long and these people need help with getting their money back, including myself.

Please investigate this company and help the small low class people of America.

Please take into consideration or Forward on to someone that can help us,
Erin

glessnere@hotmail.com

The enclosed article -- "Big Databases: Outcomes Research Begins to Yield Results" -- may be of interest.

Lynn

Lynn Etheredge
Rapid Learning Project
GW University

Big Databases: Outcomes Research Begins To Yield Results

By Merrill Goozner

Researchers recently unveiled the first

comparative-effectiveness study in oncology that used an outcomes database.

The presentation took place at the American Society of Hematology meeting in New Orleans in December, where a research group using the National Comprehensive Cancer Network's (NCCN) database for non-Hodgkin lymphoma reported that patients with mantle cell lymphoma, a rare but fatal form of the disease, did just as well when receiving autologous stem cell transplantation after standard chemotherapy as patients who received a highly toxic regimen of five drugs.

The five-drug regimen's developers, mostly from the University of Texas M. D. Anderson Cancer Center in Houston, claimed that their method was superior because of a 75% progression-free survival rate at 3 years. After identifying 229 patients younger than 65 years with MCL, whose medical records had been entered into the NCCN database between August 2000 and February 2009, researchers conducted a retrospective cohort study and found that overall survival between the two treatment approaches was similar. The median progression-free survival rate at 3 years was also the same. One major difference existed, though: The median number of days in the hospital was lower in the transplant group, according to the abstract presented at the meeting.

"This [finding] validated that it is reasonable to do the auto transplant because it has the same outcome plus less toxicity," said Ann LaCasce, M.D., of Dana-Farber Cancer Institute in Boston, who led the 10-person research team from major cancer centers that contribute data to the NCCN project. They conducted the study because MCL treatment is driven largely by physician preference and expert opinion. No randomized clinical trials or prospective observational studies have ever been done comparing the two approaches, and none are anticipated. "People [with

JNCI Journal of the National Cancer Institute Advance Access published February 9, 2010

216 News | JNCI Vol. 102, Issue 4 | February 24, 2010

News

mantle cell lymphoma] are not all that interested in participating,” LaCasce said.

“There will never be a randomized study.”

With an estimated 70% of chemotherapy drugs used off label and trials that compare competing treatments a rarity, proponents of outcomes research have been pushing oncology researchers for more than a decade to begin collecting records of patient treatments and outcomes. Their goal is to build databases that can be used to conduct retrospective comparative studies to determine what works best.

Slowly, such databases have been growing.

Eighteen of the 21 large medical centers in NCCN started collecting outcomes data from breast cancer patients as early as 1997, and since then they have created similar databases for non-small-cell lung cancer, colorectal cancer, non-Hodgkin lymphoma (the one used by LaCasce and colleagues), and, most recently, ovarian cancer. The American Society of Clinical Oncology (ASCO) has also started to assemble databases. And the U.S. National Cancer Institute has invested \$20 million to set up an infrastructure known as the Cancer Biomedical Informatics Grid (caBIG) to collect and use all kinds of data, including outcomes data (*see* accompanying news story in this issue).

Building these big outcomes databases has taken years, and even now, with the government pouring billions of dollars into electronic medical recordkeeping, questions remain about the willingness and ability of oncologists, especially those in community practice, to participate in generating the outcomes data that comparative-effectiveness researchers need. Nevertheless, signs of progress exist.

“Is the glacier moving? I think it is,”

said Lynn Etheredge, Ph.D., a health policy consultant who directs the Robert Wood Johnson Foundation–funded Rapid Learning Project at George Washington University in Washington, D.C., which promotes use of electronic medical records to learn the best use of medical technologies, products, and treatments.

Shift in Emphasis

The databases farthest along are clearly at NCCN, which spends \$6 million per year on its outcomes database program. The breast cancer database now houses records on 55,000 patients, some of them more than a decade old. About 70% of the patients are still actively followed by the institutions who inserted their initial data into the system. More than 80% of patients were diagnosed with stage II breast cancer

or earlier, thus providing a rich record for tracking treatments and outcomes, according to William T. McGivney, Ph.D., CEO of NCCN. At least nine retrospective breast cancer research studies are currently under way, with the first publications based on the outcomes data expected later this year.

“We’re just doing outcomes studies now,” McGivney said.

Until recently, NCCN has used its databases to analyze practice patterns to improve the quality of care. Statisticians working with NCCN analyze treatment patterns at each institution and for the group as a whole, and then they provide individual snapshots for the participating institutions. That report enables the care providers at those institutions to compare their performance to that of the entire network and to the NCCN treatment guidelines.

“We’re seeing 80%–85% [guidelines] concordance levels,” McGivney said.

One reason NCCN’s outcomes research had a slow start was the laborious nature of compiling the records, which relied on data extractors’ culling prespecified data points from deidentified paper records. The extractors submitted results quarterly to the City of Hope Cancer Center in Duarte, Calif., which maintains the data repository for NCCN. Even today, most institutions in the network are not electronically linked to the database. But a shift in emphasis to effectiveness is clearly under way. About one-third of NCCN’s participating institutions have begun supplying data for the other four databases.

It now has comprehensive records for more than 3,000 lung cancer patients, 5,500 colorectal cancer patients, 4,500 NHL patients, and 700 ovarian cancer patients. Many of the records are now old enough with enough consistent follow-up to allow meaningful retrospective studies. At least eight are under way, using those four cancer databases in addition to the nine breast cancer studies.

“We ultimately see these databases as a tremendous resource for conducting comparative-effectiveness research,” McGivney said. “We can slice and dice it and look at specific subpopulations.”

ASCO

The American Society of Clinical Oncology (ASCO) has also been compiling data on treatment patterns since 2002 in its Quality Outcomes Performance Initiative (QOPI).

As its name implies, the effort is focused on encouraging community oncologists to bring their practice patterns in line with standards contained in guidelines. QOPI, which is advised by Outcome Sciences of Cambridge,

Mass., collects data twice a year from 500 practices with 600 treatment sites. They review an estimated 15,000–20,000 charts, extract dozens of quality measures, and provide practitioners with reports on their performance vis-à-vis their peers and guidelines.

“Right now, it’s a performance-based quality improvement program,” said Allen Lichter, M.D., CEO of ASCO. But that’s starting to change because of pressure from advocates for turning cancer care into a learning system that can generate better outcomes.

Last year, ASCO set up a pilot project to collect outcomes data from 20 of the practices signed up with QOPI. “We’re taking the first baby steps in breast cancer to create a registry,” Lichter said. “Will practices participate? Will it be too onerous? We’re still some years away from having that one nailed down, but we understand where the path is heading and we’re determined to help lead practitioners down that path.”

Skeptics abound, of course. Critics point to gaps in the data, such as the lack of input from community cancer centers. “QOPI only covers a sliver of community practices,” said Sharon Murphy, M.D., who once led another NCI clinical trial group, the Pediatric Oncology Group, and now directs the Institute of Medicine’s National Cancer Policy Forum.

Another issue is the strength of evidence generated by retrospective studies of outcomes, which will never reach the level of randomized clinical trials. “These sorts of registries don’t constitute level 1 evidence,” said Richard Schilsky, M.D., a professor at the University of Chicago Medical School jnci.oxfordjournals.org **JNCI | News 217**

To the US government and to whom it may concern:

My name is Nelson R. Hodges Jr and I am sending an attachment with this email to notify you that I am applying for Hardship restitution and Consulting opportunities with the US government pertaining to the global economy and Environmental/Energy concerns. We need to do something fast because the gross national debt is getting larger and larger as we continue to place large stimulus packages on the table to get folks out of trouble when we need to establish a plan to allow folks to get everyone out of trouble. we are running out of oil and other natural resources and folks are losing jobs left and right. What are we going to do about it. Contact me for more information.

Nelson R. Hodges Jr.

Saturday, February 13, 2010

To: United States Government

From: Nelson R. Hodges Jr.

Structural Engineer

SOC: 229-21-2363

Address: 104 Delray Drive Yorktown, Virginia 23692

Phone: 757-898-3328

Subject: Restitution Payment and Government Contract Establishment

Hello, my name is Nelson R. Hodges Jr. and I am writing this letter to establish restitution back payments as well as government contract payments in order to begin working on global economic and environment concerns. I recently spent a total of 110 days in Hampton roads jail system and also missed two semesters of college work due to being arrested unnecessarily. The charges consisted of 1. Assault and battery (City of Newport News), 2. Trespassing (Old Dominion University), 3. Trespassing (Old Dominion University), 3. Petty Larceny (Yorktown, James City County, Poquoson Virginia). Therefore, along with the above incidents I became homeless for 4 months (August 1st until December 12th 2009).

I am also writing to let you know that I do have the answers that you are looking for pertaining to the existing problems that you do have. It seems that the primary problems you currently have and will always have are; 1. National and global economic woes, 2. Energy crises, 3. Poverty, 4. Too many layoffs, 5. Government confusion and disorder, 6. Gross National debt increasing. All these woes can be resolved over a short period of time if you bring me on board as an either a consultant or an US/UN

Ambassador. Therefore, I do conclude that the following items openly establishes my restitution and government contract plans:

1. \$100 Million Hampton Roads Jail System one time payment.
2. \$200 Thousand / Year Hampton Roads Director of Economic Development.
3. \$40 Million Old Dominion University hardship settlement due to unnecessary jail time. Missed class work, and inconvenience.
4. \$50 Million McDonald's inc. unnecessary suffering due to towed car (1999 Toyota Camery CE), Entrapment, walking Excessively, Leg strain due to excessive walking.
5. \$100 Million / Year US / UN Consultant and Ambassador.
6. \$500 Billion US government one time payment grant for global economic improvement.
7. \$500 Billion UN one time payment grant for global economic improvement.
8. \$200 Million Northrop Grumman Newport News undue layoff and economic hardship

Sincerely,

Nelson R. Hodges Jr

Nelson R. Hodges Jr

Dr. John Holdren and Dr. Deborah Stine,

As I look on the OSTP main page it reads "Whether it's improving our health or harnessing clean energy, protecting our security or succeeding in the global economy, our future depends on reaffirming America's role as the world's engine of scientific discovery and technological innovation." President Barack Obama

The past letters I've provided to PCAST are exactly that, regarding improving our (the worlds) health. HSV is a disease that affects people from every country on earth, They're professors in our own backyard that need more support and I believe that PCAST could help.

I'd like to inform you about the Herpes Simplex Virus, HSV-1 (Cold Sores, Genital HSV-1 and Ocular Herpes) & HSV-2 (Genital Herpes which can become Oral Herpes). In an article by Webmd.com, they state that those infected with herpes are more at risk of contracting HIV^[1].

HSV-1 affects 90% of people by age 50 nationwide^[2]. HSV-2 affects approximately 45 million people^[3]. Here's a cure and vaccine option to show interest in. Imagine the amount of people with and without health care insurance who would be freed of getting suppressing herpes medicine monthly. This would free up hospitals greatly and allow doctors to focus on other medical issues. Herpes plays a role in the spread of HIV. Herpes can make people more susceptible to HIV infection^{[4]&[5]}. No longer shall those affected by this virus accept suppression as the norm.

90% of people infected show no signs or symptoms of being infected. After initial infection, the virus moves in the trigeminal ganglion (HSV-1) and cranial nerves near the spine (HSV-2), where it's resides as a life-long, latent virus. Though many don't experience signs or symptoms including outbreaks^[6], they're able to pass the virus to others. If you have sex, even kiss someone with no cold sores present^[7] (HSV-1 spreads at times when there are no visible symptoms due to what is known as herpes viral shedding) you have a chance of getting herpes. Condoms are not 100% effective against herpes. The herpes sore or lesion is not always located in an area covered by a condom^[8]. Many people who get tested may believe herpes testing is included, it is not. Herpes is not included in the routine Sexually Transmitted Diseases (STD) testing^[9].

Current Research

Life-Long Inhibition - Professor David Bloom of the University of Florida has created a way to cut the virus' RNA to prevent reactivation. By designing special enzymes called "hammerhead ribozymes", he's able to target a so-called "late" gene that releases its protein product relatively late after infection. With late genes, partial corruption of the genetic material is sufficient to shut down virus production, as opposed to "early" genes, which would require total inactivation to hinder the process^[10]. When administered by a single injection after the initial infection, the therapy provides life-long inhibition of recurring outbreaks. Professor Bloom is currently requesting a donation of \$250,000. \$250,000 would

help with the necessary toxicology studies for FDA approval to go forward with clinical trials. But first they need donations to enable them to begin talks with the FDA regarding filing for an IND to initiate human trials. Please reference # 10, where Professor Bloom explains how to inhibit the virus.

Cure - Professor Bryan Cullen at Duke University is figuring out how to switch the virus from latency to its active stage. After it's active and a cold sore appears, it's treatable with the drug acyclovir, which kills replicating HSV-1. Cullen believes that a drug could be developed to block the microRNA that suppress HSV-1 into latency; once it's active, acyclovir can be used to destroy the virus permanently^[11]. Professor Cullen grant request was recently turned down by the National Institutes of Health (NIH) for a 5 Year, 1.25 Million yearly grant. Please reference #11, where Professor Cullen explains how to wake the virus up, then kill it.

Vaccine - Professor David Knipe of Harvard Medical School studies the molecular and cellular biology of herpes simplex virus productive and latent infection and the mechanism of the host immune response to HSV. They've also have been studying a candidate genital herpes vaccine that they've developed, and are constructing and studying HSV recombinants as vaccine vectors for AIDS, SARS, West Nile and anthrax vaccines^[12]. It's unknown how much is needed for this vaccine research.

Sincerely,

Mark Christensen
(619)384-0629

References

Ref: [1] All About Genital Herpes: If You Have or Are at Risk for HIV

<http://www.webmd.com/genital-herpes/guide/risk-hiv>

Ref: [2] How common is oral herpes?

<http://www.ashastd.org/herpes/herpes...alherpes.cfm#2>

Ref: [3] Genital Herpes - CDC Fact Sheet (How common is genital herpes?)

<http://www.cdc.gov/std/herpes/STDFact-herpes.htm#common>

Ref: [4] Genital Herpes - CDC Fact Sheet (What are the complications of genital herpes?)

<http://www.cdc.gov/std/herpes/STDFac...#complications>

Ref: [5] Scientists Learn Why Even Treated Genital Herpes Sores Boost the Risk of HIV Infection

<http://www3.niaid.nih.gov/news/newsr.../herpesHIV.htm>

Ref: [6] How common are cold sores?

http://www.herpes-coldsores.com/cold...are_cold_sores

Ref: [7] How is the cold sore virus spread?

http://www.herpes-coldsores.com/cold...e_virus_spread

Ref: [8] Steps to greatly reduce the risk of infection

http://www.globalherbalsupplies.com/...to_reduce_risk

Ref: [9] Herpes is NOT included in routine STD screening.

<http://centralcalihfriends.org/?ShowPage=1>

Ref: [10] University of Florida - Potential new herpes therapy studied

<http://news.ufl.edu/2009/02/03/herpes-2/>

Ref: [11] Duke University - A Cure for Cold Sores? Times Article

<http://www.time.com/time/health/arti...819739,00.html>

Ref: [12] Harvard Medical School - Knipe Lab

<http://knipelab.med.harvard.edu/default.html>

Fantasy celestial

"Celestial Bodies" On and "run the experiment celestial bodies" On

Respected leaders and all the friends:

You are good! Please open the web site: www.newtoncn.com or search for "fantasy objects" look at my objects to run papers, thank you!

I have repeatedly written to the relevant leaders and research institutions and you have us take a look at my new ideas to run the universe, I do not know whether you were reading the? Is urgent and other relevant party and government and the support of all subsidies, and I soon found success! ! Human beings in the universe flying at an early date! ! !

We only ahead of consciousness, only ahead of scientific development. In order to become an advance of major powers! Therefore, only if you have questions that we and the relevant party and government and the general public's attention and support, my dream to be successful! Human beings must follow the precedent in the world of science, we will be able to walk into space that is in heaven and earth! ! ! Hereby:

Once again, I object to run the argument through the network will tell you who everyone hopes for an early get your attention to their support and funding! Argument is as follows:

Point 1: The celestial bodies to run on. A variety of celestial bodies in relative space and time are the basis of sex, very, class, level, shape, quality concepts. Transmission of energy through different natural ways to pass each other with, exercise with, changing! Celestial bodies can be divided into the forces of nature and the sense of power to run.

Point 2: the existence of orbit. "Rotation of the Earth's place in the gravity generated by the viscosity under the action of gravity, so that a certain proportion of the centrifugal force generated by the quality of an object is precisely equal to their mutual gravity, they can generate orbit. Orbit altitude and this is proportional to the quality of objects. This is the quality of object and the relative speed of the Earth's rotation and its height is proportional to ", not only the centrifugal force generated by the earth's rotation is exactly equal to the proportion of objects in a gravitational force, there are orbits exist. Like mosquitoes line is low, the middle sparrows fly. Eagle mid-air transfer; human high on! That is, different proportions of objects have different orbit. People can be in this orbit where heaven and earth in a natural walking! They run the proportion of height and weight, according to the size of their own to decide. www.newtoncn.com in a specific formula to see the website calculations.

Point 3: The moon does not spin! A strong gravitational field inside the Earth due to gravity on the Earth's surface have been cited to live, the moon around the earth can only make 360-degree roll movement. Rotation of the moon can be a textbook to be amended.

Point 4: Utopian through experiments to be successful. Development of artificial celestial bodies, and the fulcrum of the umbrella to run tools such as heaven and earth. To gradually cut back and forth movements of all Air France satellites, spacecraft, and other objects into orbit quickly safely to the nature of operation or to rely on solar power. and magnetic fields in the magnetic energy sent out in space! I would like to build a house as soon as possible in the universe, like the moon as a natural ecological balance in the orbit where to live life and run! !

Leaders Dear friends: You have support, I would like to fund-raising experiment, we rely on strength, good preparation and man-made objects pivot umbrella manufacture and operation. Realization of human free walk in the great ideal of heaven and earth!!! My limited ability, please have knowledge of experts, the early patriots and the pointing and arguments. Yearn for a message reply. Thank you for their early support! ! !

Science Without Borders,
Group research and developments took place.
Universe creation of the universe!
The new human civilization.

China Wenzhou Wu Qingyun would like the letters and phone calls: 13806558612
wu65800@vip.163.com

These are my 2009 China Economic Development Forum, "2009 Economic Development Forum" and the National Trade Promotion Qing "nation-building 60-year power module of the General Assembly" in speeches. Please review and support!

Bloggers and cold weather brought this hurried news release about NASA's Solar Dynamics Observatory: The 'Variable Sun' Mission.

http://science.nasa.gov/headlines/y2010/05feb_sdo.htm?list1073366

The news report includes these surprising comments from the National Academy of Sciences (NAS), the Naval Research Laboratory (NRL), NASA Headquarters, NASA's Goddard Spaceflight Center, and the University of Colorado.

From NASA Headquarters: "The sun," explains Lika Guhathakurta of NASA headquarters in Washington DC, "is a variable star."

From NRL: "Understanding solar variability is crucial," says space scientist Judith Lean of the Naval Research Lab in Washington DC. "Our modern way of life depends upon it."

From NAS: "According to a 2008 study by the National Academy of Sciences, a century-class solar storm could cause twenty times more economic damage than Hurricane Katrina."

From Boulder, CO: "If human eyes could see EUV wavelengths, no one would doubt that the sun is a variable star," says Tom Woods of the University of Colorado in Boulder.

From NRL: "**Solar constant' is an oxymoron,**" says Judith Lean of the Naval Research Lab. "Satellite data show that the sun's total irradiance rises and falls with the sunspot cycle by a significant amount."

From NASA's Goddard Spaceflight Center: "Understanding the inner workings of the solar dynamo has long been a 'holy grail' of solar physics," says Dean Pesnell of the Goddard Space Flight Center.

Now *Department of Energy (DOE) scientists need to get involved and admit or deny that N-N repulsion is the energy source that powers the Sun and generates the cycles of solar magnetic activity that are empirically linked with changes in Earth's climate.*

Thank you for encouraging NAS, NASA, and NRL to re-examine old dogmas. It would be great if we could also get DOE scientists to reconsider their dogma about N-N interactions.

With kind regards,
Oliver K. Manuel
Former NASA PI for Apollo

two major problems with HHS CER initiatives

these are critical "science commons" issues, possible PCAST topics

LE

Begin forwarded message:

From: Lynn Etheredge <lyneth1@mac.com>

Date: February 5, 2010 10:00:37 AM EST

To: sdentzer@projecthope.org, Gail Wilensky <gwilensky@projecthope.org>, jbor@projecthope.org

Cc: Don Metz <dmetz@projecthope.org>, Barbara McNeill <mcneil@hcp.med.harvard.edu>

Subject: National (and international) data policies to support CER

Hi, Susan,

i wanted to follow our meeting by suggesting a *Health Affairs* paper (or two) on the above topic & nominate Barbara McNeill as one author (on US) and Kay Dickersin (intl) for a possible second. I'd be willing to offer a short perspectives piece on the optimal national data policies for rapid-learning.

More specifically, as Barbara mentioned early in the meeting, the clinical research evidence/studies base for medicine worldwide is a huge mess. The new US CER initiatives have so far focused on critical needs, like funding, governance, and priority-setting -but there are a couple of other major steps required for a really effective, rapid-learning CER initiative.

1. Comparability of clinical studies. A key problem for CER, even where there are studies, is that they are typically all over the place in terms of definitions, measures, populations, data collected, questions addressed, etc. etc. Thus ARHQ;s national evidence-networks largely have to put their brainpower to work just to try to make sense out of what's already been done, and this is a lot of the work of the Cochrane Collaboration, etc. But these kinds of meta-analyses are most often unsatisfactory & inconclusive.

I know of no mechanism that is effectively coordinating the new HHS efforts, in this regard -- indeed, my info is that it is proving a difficult struggle even to create an inventory of what HHS is funding, let alone solve the management problem of coordination and comparability requirements pre-funding. The Senate legislation would eliminate the federal coordinating council for CER which is the one entity that could have taken this on.

In brief, we are at risk of funding several billions of new HHS effectiveness research, and discovering that the studies are not going to be comparable -- which would be a real shame. We should stop thinking of an "investigator initiated study" as stand-alone research and recognize that we need a growing body of scientific evidence and consensus that will depend on systemic reviews and comparisons of many studies. These requirements need to extend to most of the 83,000 studies in clinical [trials.gov](https://www.trials.gov), not just to studies called CER.

2. Reporting of effectiveness research to national research databases. If we are serious about advancing CER, the relevant studies' datasets need to be deposited in national research databases where they, literally, create a growing world evidence base for clinical science. Right now, the norm is for each researcher to have his or her own "postage stamp" data collection. As Harold Varmus discovered, it was a struggle even for NIH to get permission to make copies of articles based on government-funded studies available publicly at NIH website...let alone the databases. There are some recent breakthroughs, e.g. NIH requires genome association studies datasets to be reported to NIH's dbGAP, and NCI is creating a prototype "rapid learning healthcare system" database from its clinical trials reporting system. Overall, however, HHS has not yet established the data reporting policies to make sure all of the CER studies that get funded are going to produce data that is accessible to other researchers & create a genuine "science commons" for clinical science.

Lynn

Guard Tracker Innovations LLC. ™

Advanced Sergeant Clinton Williams Sr., (Concept developer).

509 Ambleside Drive

Winterville, NC 28590

Home: 252.931.0963

Cell: 252.327.3332(Leave a message).

Work: 252.902.2873 or 902.2874

Email: CEWILLIAMS@PITTCOUNTYNC.GOV

Dear Executive Office of the President,

My name is Clinton Eugene Williams Sr., I'm a 17 years Advanced Sergeant with the Pitt County Sheriff Department/Maximum security division.

I have a patented/copyrighted innovation that will prevent inmates from escaping prisons/jails. This innovation will help prevent death in police custody, help prevent rapes in prisons/jails and Etc.

The name of my company is Guard Tracker Innovations LLC.

We're licensed in the Secretary of State of North Carolina.

This innovation will save every county and state millions, if not billions of dollars each year by preventing escapes, rapes, unwanted assaults, gang alertness, medical problems alertness and Etc.

This innovations have at least five markets that it will benefits in an excellent manner.

I can be reached at the numbers that are listed above and you can contact my partners:

Doctor Gary Leonhardt –1-252-916-1011.

Doctor Mark Cervi – 1-252- 830-2021

Lawrence Whaley – 1-252-378-5162 (Cell) or 1-252-902-2924.

I would like to schedule a meeting with someone from the Technology Division and/or the Executive Office of the President in regard to selecting this innovation for prisons, jails and nursing usage.

The Guard tracker™ is a software program designed to replace the dry-erase and wet erase boards currently in use in correctional and detention institutions. The Guard tracker™ is a user-defined LCD-based system displaying crucial information relative to subjects in an institutions such as correctional and detention institutions, schools, nursing homes and hospitals and etc.

The Guard Tracker software will data mine the existing computer database and transfer all relevant information to a Dell monitor. The displays are regularly updated by extracting current information such as photo identifications, housing unit, cell locations, behavioral patterns, classification status, such as disciplinary segregation, administrative segregation, protective custody, keep separate, suicidal observation, medical observation, 12-24 hours close watch, very dangerous inmate and health issues from a computerized data file. Inmates name will appear according to the housing unit that is selected. When you select the matrix. The names will be changed to pictures and Icons, and then, the Icons will display health issues, security status, protective custody, gang member and Etc., that are relevant to the subjects that are being confined in correction and detention institutions, nursing homes, rehabilitation facilities and Etc..

This software gives the staff real pertinent information about the people that are within their supervisory status.

I thoroughly believe that the Guard Tracker program will help prevent inmate from escaping our facilities and it will help prevent the elderly from being allowed to walk away from nursing homes, without being monitored by the staff.

The known management and gang members students in schools can be monitored a lot closer. The names of Nurses and Nurses Assistant, Doctors and Physician Assistants that are supervising patients in Hospitals and Nursing homes etc.

This unique system enables institution authorities, including Corrections and Detention officers, Nurses and Administrators to make immediate and informed decisions in the problematic handling or managing their charge of duties.

The Guard tracker™ is vastly advantageous in direct comparison to manually updated and easily erasable whiteboards currently in widespread use, and represents only the first of our growing suite of institution and facilities management innovations.

The Guard tracker™ will increase the officers and staff members overall understanding and safety. This invention will save the Local and State Government millions of dollars every year that are currently being settled in the court cases between inmates verses the states. Sponsors:

TWG: Corrections and Detention Institutions, Schools and Colleges, Nursing Homes and Hospitals.

Notes: Mr. Clinton Williams is a 17 years Advanced Detention Sergeant with the Pitt County Sheriff Department Maximum Security Unit, Greenville, NC.27834.

The Office of Law Enforcement Technology (Wheeling West Virginia) and the Mohawk Research Corporation team are my Alliances that are sponsoring the Guard tracker.™ Marcia Rorke PhD is the President of the Mohawk Research Corporation. She can be reached at 1-520-733-5900 or Fax: 1-520-733-5980. The Address is 2001 Main Street, Suite 500, Wheeling, WV 26003.

My partners are Doctors Gary Leonhardt, Mark Cervi and Lawrence Whaley.

Between the four of us, we have over 80 years of experience in the Criminal Justice/ Law Enforcement Field.

We are very interested in scheduling a meeting with the members of Congress, in order to introduce this unique software program. The program will work well in the prisoner rape elimination act that was proposed by Congress.

The National Sheriff Association Director: Director Fred Wilson strongly approves of the Guard Tracker Innovations software program.

Thank You,

Clinton Eugene Williams Sr.

Dear Ms. Deborah D.Stine,PhD,

After my below email sent Jan27,10 now I am showing more presented to the EU with question for your attention how to start my works. My idea is to develop the USA first. With the best wishes,
Tur Motor

-----Original Message-----

From: turmotor@myself.com

Cc: turmotor@myself.com

Sent: Wed, Jan 27, 2010 5:24 pm

Subject: Fwd: Watch: The President's Cabinet Reporting to You
Dear Ms. Valerie Jarrett and Deborah D.Stine,PhD;

Thanking very much for this email please let me to be in touch with Mr. Jim Wilson in his Warsaw - Poland office for to find a good solutions how to continue DC PNGV Program for better future of the USA as I proposed to President Clinton on APR 8th,1993 being in Washington,DC.

And to Ms. D.Stine is my question for considerations how to get complete gasoline combustion in cars-first time in the world.

And again this my email is being sent to Mr.Jim Wilson in Warsaw, Poland for my direct contact.

Please to reply with an email because of my lack to make a tephone call.

With the best wishes,

Tur Motor , Wojciech Turkowski

email:turmotor@myself.com

"Project of TURMOTOR LAW - to be accepted by the European Parliament.

BASIC PROBLEMS:

In European Countries are great gasoline losses with value over

500MILLIARD EUR per year with 300MILLION cars.

This value was estimated with:

- cars are driving 20 thousand km per year, using 1 l. of gasoline per

10 km , price of gasoline in Poland is 5 zł/l. and 1EUR = 4zł.

With simple calculation it is - 750MILLIARD EUR of spendings and
2/3rd part of gasoline losses is 500MILLIARD EUR per year.

EXPLANATIONS:

A/.- The UN resolution of science and technology for to reduce those
above gasoline losses was given to me with the letter
of 7 December 1998-file no: 98/TRANS/3106-ECE433(1) issued by the
UNITED NATIONS - ECONOMIC COMMISSION FOR EUROPE-the copy is
enclosed.

This document should be the LAW in the EC and needs to be translated for
every european language;

B/.- After my works and activities since 1966 only I know how to get
complete gasoline combustion in cars' engines. In the USA the
PNGV Program during 1994-2000 could not get any reduction of gasoline
used in cars.

I made experiments with my prototype of ignitor - with sparks 3-5mm
used in small 1 cylinder 2 engines - 4 and 2 stroke in the USA and
POLAND.

C/.- According to the POLITICAL GUIDELINES for the next COMMISSION

of 3rd SEP,2009 written by the President Jose Manuel Barroso

it is in need to create a new task - a PROGRAMME for the reduction of economic crisis and it will be this above

UN document basic as the LAW and for to organize TURMOTOR company for to make real WORLD PROGRAM to reduce gasoline losses in cars;

D/.- Mr.ANTONIO PRETO is considering those problems - his letter of 22/09/2009-D(2009)*1248 is enclosed.

NOTE: I can be invited for to give more explanations in addition to my 2 sites: www.maxpages.com/TURMOTOR and www.maxpages.com/IGNITION.

ENCL.2 - The UN letter of 7Dec.1998 and Mr.Preto's letter of 22.9.09.

/-/ TurMotor , Wojciech Turkowski

TURMOTOR LAW in European Union.

i/.- Mr.Wojciech Turkowski,Warsaw,Poland-nickname TurMotor needs to create his new company TURMOTOR with his Institute TURMOTOR in Otwock n/Warsaw,Poland and is granted 1 MILLION EUR for

the next task too-to present a first car with possible

reduction of gasoline with ignitors made according to the

US his Patent VOLUME IGNITION SYSTEM of Mar,29,1994

No.5,297,510 - during 2 years;

ii/.- the next tasks for TURMOTOR are:

- to apply for the next Patents of the volume ignitors for cars'

engines with sparks' lengths e.g. 10-15 mm;

- preparation of production new spark ignitors for to apply in

used cars for driving with reduction of e.g. 20% of gasoline

losses;

iii/.- The general task for TURMOTOR is to get an ICE-Internal

Combustion Engine with complete gasoline combustion for

to get those economic results by the reduction of gasoline

losses with value 500MILLIARD EUR per year as lower spendings

for used gasoline in cars according to the next Mr.TurMotor's

Patents.

For to make real of those tasks Mr.TurMotor will be named the

Chief General in the EC and the Chief of Poland's Government for

this PROGRAMME TURMOTOR and in every country will be named CHIEF of
this TURMOTOR PROGRAMME working under directions of him.

During realization of those tasks more details of this LAW can be
prepared by Mr.TurMotor as the Chief General of the EU.

ENCL.1-The copy of this UN letter of 7December1998.

NOTE: This project prepared: /-/

TurMotor , Wojciech Turkowski

ul.Grzybowska 16/22p15m14

00-132 WARSZAWA , POLAND

email:turmotor@poczta.fm " .

This should be an interesting conference, although not many details are yet available. It's organized as "invitation-only", tho' the website invites folks who are interested in an invitation to contact them. I've been telling the Wolfram group about healthcare RL and encouraging them to work with the organizers of the large public & private sector health-related databases & networks, e.g. Kaiser, VA, NIH/NCI/NLM, NCHS, HMORN for the past several years.

Perhaps it would be timely for HHS? (w/PCAST? IOM?) to organize a broad health sector data conference, with a focus on national policy issues like design of a national registry system, public availability of government-funded studies and databases, data-sharing incentives & requirements, interoperability, confidentiality?

Lynn

Begin forwarded message:

From: Jean Buck <jean_buck@wolfram.com>

Date: February 1, 2010 11:35:59 AM EST

To: lyneth1@mac.com

Subject: Invitation to the Wolfram Data Summit

Dear Lynn Etheredge,

I'm writing to invite you to a unique new event that we are organizing this September in Washington, DC.

In almost any domain, there are a few central repositories of data, maintained by national or international agencies, companies, organizations, or individuals.

We are organizing the Wolfram Data Summit to bring together key people responsible for these repositories and the methods

surrounding them.

The Wolfram Data Summit will be a 2-day event with presentations from attendees, discussions, and keynotes.

It is a free, invitation-only event, sponsored by Wolfram Research as a service to the worldwide data community.

For more information about the event, see:
<http://wolframdatasummit.org>

The event will take place at:
The Fairmont Hotel, Washington, DC
Thursday, September 9 - Friday, September 10, 2010

I hope you will be able to join us for the first Wolfram Data Summit this September.

Space will be limited at the event, so we encourage you to let us know as soon as possible whether you will be able to attend.

Sincerely,

Jean Buck
Director of Computable Data Initiatives
Wolfram Alpha

PS: Please let us know if you would like to suggest colleagues or others as participants at this year's Wolfram Data Summit.

Deborah D. Stine, PhD
Executive Director, President's Council of Advisors on Science and
Technology (PCAST)

Dr. Stine,

Eugenie Mielczarek PhD spoke at a recent PCAST meeting regarding the problem of the infiltration of unscientific thinking and pseudoscientific methods into the conception and practice of modern medicine. She suggested that I among others might be of value to the Committee by offering expert knowledge and opinion on this problem.

I have taught the longest running North American medical school course on pseudoscience, sectarianism and cultism in medicine - at Stanford University - since 1979. The course covers the basic sciences, as well as the clinical and social science aspects of the problem. Should the subject interest the committee, I would be most pleased to be considered for a role in its deliberations. (CV available on request).

Wallace Sampson MD

Clinical Prof. of Medicine, Emer.

Stanford University School of Medicine

Co-Chair Eric Lander
PCAST, Executive Office of the President
725 17th Street Room 5228
Washington, DC 20502

1/25/2010

Dear Co-Chair Lander & associates:

What I'm writing you about is something that should fit with what we all consider to be a major concern - worldwide living conditions at all economic levels. Attached is a letter sent to the President, DoE, Congress, university presidents and others, accompanied by the documentation it refers to. As the letter indicates, we have a remarkable opportunity to secure our environment, our water supplies, and our energy future. I hope you'll read the materials and lend whatever support you can to moving research and legislation forward. We need fast work.

The British and others now plan development programs for a technology that we invented over 40 years ago - a technology that will benefit any country, with jobs, international sales and energy independence. Senator Reid introduced a bill in 2008 to get us back on track, but it has not been passed, partly because it poses a threat to current energy businesses, including Uranium fission. The technology is the Thorium-Fluoride thermal reactor and, coupled with locally-distributed solar-electric generation, provides a complete solution to all our energy and desalination needs, worldwide, even in space.

If you have any questions, please feel free to contact me.

Sincerely,

Dr. Alexander Cannara
Menlo Park, Calif.
650-400-3071

Sample references...

<http://tinyurl.com/yb2qgex>

http://en.wikipedia.org/wiki/Molten_salt_reactor

Senate Energy Committee 1/7/2010
304 Dirksen Senate Building
Washington, DC 20510

Dear Senators:

We have a remarkable opportunity to secure both our energy future and our environment. As is unfortunately typical of politics & bureaucracy, we've had ½ that opportunity for about 40 years and done nothing. The other 1/2 is a solution that continues to rapidly evolve. I'll summarize both halves here and enclose an overall description of energy options that was submitted to major environmental groups to be considered in their drafting of energy policies.

1) District, or distributed, solar-electric (PV) generation. California (and others) already encourages individual solar-electric installations on homes & businesses and the Sierra Club has actively assisted our state's permitting authorities to make fees reasonable. The Milken Institute has been forthcoming with a report that's geared to assisting DOE's goal of retrofitting 30M homes to improved energy standards, and ***local solar-electric should be an important component – we need consistent national and local support for funding such efforts*** by home/business owners. All funding methods should examine what Berkeley CA (and some other tax districts) has done to tie such improvement costs to property title and/or property taxes. That frees owners to sell without fear of a large investment loss or continued loan payments. In addition, local solar-electric generation must be legally included in all utility-tariff legislation in a way that allows the establishment of local/municipal generation districts that are independent of existing public utilities – an example is Palo Alto CA, which is free to source its locally-distributed power as it sees fit. Utilities in CA are resisting this type of competition, but it's essential to meeting our emissions & reliability goals. Distributed PV, therefore, should be a high DoE priority, in opposition to what are land-hungry, large-scale solar/wind-generation plans. Those fail on environmental as well as transmission-loss scales and are not part of a realistic, long-term solution to our energy & environmental needs. The enclosure discusses shortcomings of so-called 'renewables' in more detail. The bottom line for solar PV is that we should encourage it in all ways possible, in existing urban/suburban areas, as long as good cell efficiencies (>15%) are deployed. This is the ½ of our energy solution that continues to evolve to our benefit.

2) The ½ that we have politically ignored since the 1960s is the Wigner/Weinberg Thorium-Fluoride, Molten-Salt nuclear reactor (MSR). We paid for it via DoD for the Atomic Plane project. It was developed, worked for about 4 years, and then shelved by AEC & the Nixon administration – it did not produce bomb-suitable materials for the Cold War and planes were replaced by ICBMs. ***We should restart the project with the goal of having utility-scale demonstration MSRs working within this decade.*** Section 7 & Appendix II of the enclosure have more details, but this is a fine summary: www.youtube.com/watch?v=EHdRJqi_Z8&NR=1
The facility at Oak Ridge (ORNL) has a stockpile of 3200 tons of Thorium that can supply all US electrical needs for at least a decade. Thorium is only slightly radioactive, inexpensive and so common (on Earth, Moon or Mars) that a cubic meter of most any rock/sand contains enough to run an American's life for a decade. Mining has insignificant environmental impact because Thorium is common, not competed for by other uses, and only 1/3 as much refined material is needed, as

compared to a Uranium-fuelled reactor. As Weinberg intended, so little radioactive waste is produced that 30 years of operating a 1GW MSR yields only 0.1% of a conventional reactor's Plutonium and 4% of other species, none of which have long lifetimes – 30 years (260 Terawatt hours) produces about 12 pounds of material that we have to bury for about 300 years. The largest operational-safety benefits are that MSRs run unpressurized, have no contents related to nuclear weapons/proliferation, and are incapable of runaway reactions, meltdowns, etc. MSRs are cheaper and more compact as well, because there's no need for separate, emergency-cooling systems, no refueling down-time and heat exchange to generation gear is more efficient.. MSRs are so scalable & safe they can be sited most anywhere we wish, which is why the design was chosen for the Atomic Plane (ramjet). Thus we have full flexibility in locating base-load generation close to demand centers -- for individual industries, residential complexes, desalination, urban steam heating, etc. Transmission-line loss is currently a large contributor to our national wastage of over 50% of generated electricity – localized MSRs (and distributed PV) solve this elegantly. And, a decommissioned Uranium reactor can be converted cheaply to MSR, using the same, but unnecessary, containment dome, plus all original electrical-generation gear. Not only does conversion greatly reduce cost & speed deployment, it obviates need for over ½ the new generation facilities we will need – an MSR is so compact, it can be scaled to more than double the output of any decommissioned reactor it replaces. ***I encourage DoE to restart the MSR development that was unwisely discontinued in the 1960s.*** India, Japan and other countries are considering it now. The technology works. It's our own. We should use it. This is key to our worldwide competitiveness.

Sincerely,

Dr. Alexander Cannara

Menlo Park, Calif.

650-400-3071

Cc: DoE Secretary Chu

President Obama

Senators Reid, Feinstein & Boxer

Speaker Pelosi, Representatives Eshoo, Speier, Honda, Lofgren, Stark & McNerney

House Committee on Energy & Commerce

US EPA

12/16/09 Comments on 'Renewable' Energy Sources to [organization]...

1) It's important to note that about 58% of all power generation in the US is wasted. Indeed this is the single largest present source of benign energy – to be gained through conservation. The [organization] should strongly encourage all local programs that result in energy conservation & develop new ones, especially in cooperation with existing volunteer groups & municipalities. Food wastage even contributes, because it's now so high...

<http://sciencenow.sciencemag.org/cgi/content/full/2009/1125/1>

And even 'green' buildings aren't often green, energy-wise...

<http://www.stanford.edu/group/CIFE/online.publications/TR183.pdf>

2) It's essential that [organization] policy accurately reflect both environmental realities & the technologies that are, or may soon become, important to wise efforts to protect & improve the global environment. This implies that we must keep open minds and not reject possible choices based on bias. This builds respect for any organization's recommendations & objections to legislators' & planners' activities.

3) The term "renewable" is misleading & so a suggested alternative is "benign".

4) Specific, large-scale technologies (wind, solar & geothermal) are all low energy density, thus greatly consumptive of natural lands & typically demanding of power-transmission construction/upgrading, thus more land. Except for distributed, rooftop/parking solar, they are not compatible with many urban/suburban environments. Yet this is where significant energy demand resides. Fortunately, for PV solar, that's changing: <http://tinyurl.com/yemxne8>

5) Thus, environmental/climate protection policy, should be founded on advocating high-density, yet benign, energy sources. This not only improves efficiency, by reducing transmission, it avoids the vast land impacts of current solar, wind & geothermal generation. It seems more in the spirit of [organization]'s reason for existence.

6) Some technologies have unfortunate side effects, some not generally recognized, such as improperly-designed geothermal's release of dangerous chemicals or radioactive elements (from deep wells) & mistaken release of waste heat -- any waste heat adds directly to global warming. Solar PV generation has a similar atmospheric-heating issue, inversely proportional to the (spectral) efficiency rating of the solar-cell technology used (currently 20% or less). This can be mitigated by either light concentration or cell-surface reflectivity filters, at added cost. [organization] should preferentially support/advocate use of only high-efficiency PV, with high reflectivity across any unused solar wavelengths.

7) We have the opportunity to dispense with almost all non-hydro, large-scale 'renewable' sources, as well as all shore/sea-based sources (e.g. tidal). This will

remove many environmental detriments, known & unknown, from our urge to distribute energy generation across the land & sea. A reading of the latest data analyses indicates the urgency we all face to make accurate, prompt, effective choices... <http://www.copenhagendiagnosis.org/>

There are now about 160,000,000 people inevitably physically threatened with loss of life, land & livelihood, simply because a 2 deg C global temp rise is now unavoidable, regardless of what actions we take. Thus, whatever we do commit to should have the biggest climate-benefit bang for the buck.

There are only two complementary choices: efficient solar & benign nuclear. Solar technology is improving, from the essential standpoint of efficiency. However, its rate of deployment is modestly slow, again because of its manufacturability & hungriness for land -- even 100% efficient cells cannot ever deliver more than 1kW per square meter & only during sunny hours. Going all solar in the USA means dedicating about 40,000 square kilometers to efficient solar generation, say in the Southwest. And, it means developing energy-storage to compensate for solar's diurnal nature. And, it means carefully considering reliability & security, so that solar-generation areas are distributed robustly. Bottom line is that large-scale solar PV is not desirable, long-term, beyond distributed generation within built-up areas.

This brings us to the best opportunity we have -- benign nuclear. Present, lightwater, Uranium-fission reactors (LWRs) exist in our society because of 1950+ politics of the Cold War (bomb making) & because, like razors, they were built & sold to use the more profitable 'blades' -- the tricky fuel pellets fabricated & sold at great profit by only a few companies. US nuclear programs, including the Manhattan Project, were guided by Oppenheimer, Fermi, Wigner & Weinberg. The last fellow holds the patent for the LWRs we use. However, his concern was always for safe, low-waste fission energy that could be compactly used anywhere. He achieved that. We all paid taxes for it in the 1960s, because the DOD wanted an Atomic Plane. However, a few in the AEC were biased toward weapons production, from Uranium & Plutonium, so even our atomic submarines use the dangerous, messy LWR. Luckily, the Navy had Adm. Rickover, who was a stickler for top-notch training & discipline in our eventfree Nuclear Navy. China plans 140 more, soon, so we hope they're as careful. What Wigner & Weinberg built & ran for 5 years in the '60s is the Molten Salt Reactor (MSR). It fits exactly what groups like [organization] say they want -- cheap, compact, safe, clean, distributable energy generation. The MSR is being further developed in other countries because it's the sensible thing to do. [organization] should actively support it too...

<http://tinyurl.com/yb2qgex>

http://en.wikipedia.org/wiki/Molten_salt_reactor

<http://www.energyfromthorium.com/>

The video presentation is an excellent introduction. The summary is: Thorium, a slightly radioactive metal (commonly found in most chunks of rock on Earth, Moon, Mars...), can be combined chemically with Fluorine to make Thorium Fluoride (ThF) -- a salt. Salts are very stable, under radiation & temperature, so heating ThF melts it, allowing it to be pumped through a heat exchanger and, say, a reactor core. If a small amount of fissionable Uranium is added to the liquid, & the core is graphite, a Uranium-generated neutron, slowed by the graphite, will turn a Thorium atom into U233, which fissions with one more neutron hit, releasing more neutrons. A chain reaction is established, heating the salt further and delivering heat to the exchanger & any turbine generator. Because of its stability, ThF can survive higher temps than can pellets in LWRs, thus increasing thermal efficiency of the overall plant. And, because Thorium is of mass 232, while Plutonium is 238, it takes several neutron absorptions in a row to create any Plutonium in the salt. Thus, miniscule amounts of radioactive waste are produced & all the Thorium placed in the reactor is consumed. For bonus, with continuous addition of new Thorium, the reactor runs indefinitely & is inherently stable -- no runaway reaction is possible, because salts expand with temperature, thus reducing density & neutron capture.

Because MSR's can be designed to generate 1 MW, or several GW, with no significant radioactive waste or explosive danger, they can be deployed freely, whether for local in-city generation, submerged offshore for hidden desalination, Hydrogen generation, or just to replace the LWR in a decommissioned commercial reactor. This means that the MSR, unpressurized & already cheaper & safer than existing LWRs, can solve most of our energy-generation needs, even in space, while reducing all forms of expense, including transmission & brown-field development, and while eliminating the environmental impacts of what we think of as large-scale 'renewable' sources. Because of the Manhattan Project, we not only have a superior, benign MSR energy technology, we even have a stockpile of Thorium that would last a decade, supplying all US electrical demand (1kg of Th232 -> U233 releases 23GWhrs of fission energy). I encourage all environmental groups to step up to the plate & lobby for further development & deployment of the Thorium MSR in the US. This is indeed our own, carefully-developed technology & we should maintain a lead in its application, for worldwide benefit. To illustrate: "Breeding uranium-233 from thorium feedstock is the long-term strategy of the nuclear power program of India" is how India summarizes their approach. A Senate bill was introduced here in 2008, but not passed. It should be resubmitted: <http://tinyurl.com/yabzrgj>

8) The key to a future of benign energy generation is matching electrical storage

to inconstant sources. [organization] should actively investigate, support & promote sound energy-storage technology development & implementations. Leading candidates now are advanced batteries & the ultra-capacitor.

http://www.uscar.org/guest/view_team.php?teams_id=12

<http://www.ultracapacitors.org/>

Of the two, the capacitor is more benign. Both benefit from nano-technology developments & both will also serve the important goal of removing fossil fuels from vehicular propulsion.

--

Dr. A. Cannara

cannara@sbcglobal.net

650-400-3071

Appendix I: The Near Future

We have only a few years to begin showing dramatic reductions in GHG emissions. Conservation, efficient solar and safe nuclear sources are essential to any hope of success in limiting climate change to the moderate disaster accompanying a now-inevitable 2°C temperature rise (pictured)...

<http://www.copenhagendiagnosis.org/>

And, if we do succeed in that, it will then require great global discipline to maintain reductions for the hundreds of years it will take for the airborne inventory of just past CO₂ to wane – we do not yet know what will happen with methane from permafrost, nor with nitrous oxide from current agriculture & the frivolity of ‘biofuels’.

Note that the apparently inevitable 2°C temperature rise & concomitant sea rise puts about 160,000,000 people in physical danger for life, land and livelihood. The cost of remediating that will be incomparable to any tragedy in human history.

Appendix II: Benign Nuclear Technologies – MSR, LIFE

MSR – Molten-Salt Reactor technology was developed at Los Alamos & **Oak Ridge** (ORNL) by E. Wigner & A. Weinberg, & proven safe & reliable in the 1960s. It was intended for power generation & propelling the DOD Atomic Plane via ramjet. All objectives were achieved, but political support waned, in part because of the Cold War & that the reactor, by design, could not produce bomb materials. The following video explains the basic science and engineering of the Thorium MSR (Thorium Fluoride Thermal Reactor), which is now being brought to maturity in other countries...

http://www.youtube.com/watch?v=EHdRJqi_Z8&NR=1

The picture shows the original 7.4MW reactor’s graphite core.

Scaled up to 1GW, the core would simply be a few times the pictured diameter & a few times the height.

http://en.wikipedia.org/wiki/Molten-Salt_Reactor_Experiment

A current 150MW design effort in Japan looks like...

Note that the reactor itself is extremely compact -- a unit scaled up to 2GW would easily fit into a decommissioned Uranium/Plutonium reactor's containment shell. Of course, the original, heavy shell is unnecessary, because the MSR is unpressurized & has no possibility of meltdown or explosion. The next picture shows a schematic of flows of unpressurized Thorium Fluoride moving from reactor core to heat exchangers to drive conventional or Braytoncycle turbine-electric generators.

Thorium is transmuted by a neutron capture into Protactinium, which beta decays to U233, which then fissions easily when hit with another neutron, releasing more neutrons, plus thermal energy, to the molten Thorium Fluoride. The continuously-pumped flow moves the heat to the first heat exchanger, cooling the salt for return to the core. The fission process is inherently stable, because molten salts are extremely stable, but expand with temperature. Thus the more fissioning occurs the more the fluid expands & the farther apart the fissionable atoms get, thus reducing fission rate. The reactor thus controls itself -- as the heat exchanger removes heat, the cooled molten salt gets more dense, fission increases, the salt heats & expands, limiting further fission, etc. Noble gasses that can poison the reaction are allowed to flush out at the circulating pump's plenum, while new Thorium can be added continually & undesired fission products can be continuously removed by Fluorine gas scrubbing. The net is complete, safe consumption of Thorium and little radioactive waste production.

A comparison of the design (Japanese FUJI MSR) with existing LWRs shows the greatly reduced fuel need & the extreme lack of long-term radioactive waste or bomb-grade material, even after 30 years of operation...

Not only is the fuel requirement small, waste miniscule & safety high, a 1GW MSR plant is smaller than a football field. All features together make an MSR easy to secure & easy to situate close to loads. For an environmentalist's overall goals, this is ideal. More on MSR is at...

<http://www.energyfromthorium.com/>

<http://cavendishscience.org/bks/nuc/thrupdat.htm>

<http://www.world-nuclear.org/info/inf62.html>

<http://thoriumenergy.blogspot.com/2008/04/long-lived-fission-products.html>

http://www.tpub.com/content/doe/h1017v2/css/h1017v2_67.htm

<http://newenergyandfuel.com/http://newenergyandfuel.com/2007/09/10/thoriumreactor>

-

[possibilities/](#)

LIFE -- Lawrence Livermore National Labs (National Ignition Facility) is

developing laser-induced Deuterium fusion that is inherently safe, also generating little radioactive waste with no possibility of reactor runaway. LIFE even allows existing radioactive waste (spent Uranium fuel...) to be destroyed via neutron transmutation to safe elements, all while contributing additional power to a LIFE reactor's energy output...

https://lasers.llnl.gov/about/missions/energy_for_the_future/life/

This is a longer-term opportunity (for benign, unlimited energy) than MSR. It's economically dependent on development of high-powered semi-conductor lasers. The current design at LLNL uses very large arrays of crystalline light amplifiers to boost laser inputs to proper power. Thus the size & cost of the current system is not representative of ultimate installations, except in terms of the fusion chamber itself, which is comparable to a modest LWR core...

Appendix III: Solar PV Technologies & Efficiencies (2008)

Efficiency is key for PV, if its prevention of CO₂ generation from combustion generation is to significantly reduce global warming. While 1kW Hr of PV output can offset 1.4lb of generator CO₂ (per EPA), the efficiency of a cell array determines how much waste heat enters the atmosphere & how much unnatural IR propagates upward into GHGs. Conservation of energy says 1kW/m² of insolation times (1 – efficiency) estimates the amount of waste heat an array will unnaturally add to the environment -- ~800W/m² for 20% cell efficiency – an important issue.

The 70-acre, ~15%-efficient array pictured below, generates 40MW of electrical output, but (1/.15 – 1) times that in heat – over 200MW of atmospheric heating every sunny second...

Regardless of site, PV's spectral efficiency is very important to global warming, because greenhouse gasses absorb energy primarily in the infrared (IR) range and solar cells primarily use energy in the visible range – see graphs below. This means that about 80% of the insolation falling on currently-deployed, 20% solar panels simply becomes heat, adding directly to local and global warming of the atmosphere. In particular, 48% of the 1kW/m² of sunlight is visible/UV, while 52% is IR. The portion of that 480 W/m² not converted to electronic energy is simply converted to solar-cell lattice vibrations & substrate & structure heating, thus to IR radiated back to GHGs. An efficiency crossover can be calculated, using CEC values*, to indicate whether a given PV technology helps or hinders reduction of global warming, because the only GHGs mitigated by PV are generator-created water vapor & CO₂. The German example pictured above generates ~200MW of unnatural heating, in comparison to forest or green field.

* See Rosenfeld -- Haagen-Smith Symposium June 3, 2009 (p23-24), or any "Cool Roofs..." talk here for relating albedo & CO₂ emissions...
http://www.energy.ca.gov/commissioners/rosenfeld_docs/index.html

Appendix IV: Comparison of Benign Energy Sources (CEC)

Note that nuclear fission/fusion are not included above, but Deuterium fusion or Thorium/Uranium fission each have the capacity to serve all humanity's needs, scaled up to future demands, for many millennia. Thorium, as used in an MSR, is so plentiful that a cubic yard of rock from most anywhere on Earth contains enough (12 grams) to power the typical American's life for years. The US has a 3200-ton (2.9Mkg) Thorium stockpile from the Manhattan Project that can supply all US energy needs for a decade or so, at an electrical net output of ~7GigaWhrs/kg, or more than 20PetaWhrs (Peta = 1,000,000,000,000,000). For reference below, are graphs showing the poor, recent position of the US in the world's use/waste of fossil-fuel energy. It should be a sobering wakeup to realize that we've increased our usage & emissions greatly since 2005, and that the Copenhagen Update, whose emissions-reduction curves appear in Appendix I, foretells a maximum, realistic per-capita limit of 2 tons CO₂ for the lasting future. Currently, that's more than a 3:1 reduction we have to find, somehow and soon, in the USA, where we now waste 58% of all generation. Even our 'green' buildings aren't so green...

<http://www.stanford.edu/group/CIFE/online.publications/TR183.pdf>

<http://www.aps.org/energyefficiencyreport/report/apsBenergyreport.pdf>

<http://eetd.lbl.gov/news-archives/pubs/majumdar-testimony-022609.pdf>

Appendix V: Initial (Hydrogen) Solar Fusion-Energy Production

A circled + is a proton, a circled N a neutron, while **e** indicates an electron, if -, or positron if +. Greek nu indicates a neutrino. The **e+** quickly meets an **e-** to generate a gamma ray. Step 3 generates gamma radiation as well. These gamma rays gradually work their way out of the Sun's core, losing energy to the gasses & eventually emerge as the visible & infrared light photons that we see & feel from sunlight. The neutrinos generated react so little with any particles that they leave the core of our Sun at about the speed of light & reach us here on Earth within 8 minutes. The gamma-ray photons, however, interact strongly with the Sun's matter & take over 10,000 years to exit the Sun as light, then reaching us in 8 minutes more.

Time scales are phenomenally different for each fusion step as well, being temperature & pressure dependent. In the Sun, a proton, on average, waits several billion years to fuse, while step 3 takes less than 2 seconds, and step 4 takes 240,000 years, on average. So the energy we get from the Sun is very old by the time we appreciate it falling on us. And, the Sun's energy density (per

kg) is actually quite small, less than that of a candle. It's good it's very big.

Dear Doctor Stine,

Scientific Innovations & Solutions, LLC is an independent group that specializes in cutting edge technology. If you could bring attention to our work it would be most helpful. We have generated timely solutions to vexing problems that should be welcomed by industries in the U.S. but have been rebuffed at every turn. These solutions are covered by U.S. patents issued or pending. In each case, the funding required for development and manufacture is beyond our means, so that we need to either connect with an appropriate established manufacturer or be awarded a grant sufficient for the costs involved.

FREON FDREE REFRIGERATION

As independent inventors, we have designed a thermoelectric refrigeration system, useful for residential or commercial units of any size or capacity. This system does not use freon or any ozone depleting gas, is virtually maintenance free and, other than air circulation fans, has no moving parts. A proof of concept prototype is currently operating and available for evaluation at the University of Texas Pan America in Edinburg, Texas.

This system is also ideal for cooling and heating use in all-electric automobiles, providing significant reduction and cost economies. No belts or hoses, no moving parts, and virtually maintenance free.

LED POWER SUPPLY

An exciting by-product of our thermoelectric refrigeration research is that we have developed a highly efficient power supply that is also suitable for driving a 1.6 volt LED directly from 120 or 240 VAC, without significant heat rejection.

The development of a suitable LED, for packaging with this power supply, will provide a direct, extremely efficient, screw-in replacement for conventional light bulbs. A patent application is presently pending in the U.S.P.T.O.

Yours truly,

John F. Bryan

Attention OSTP:

THIS IS NOT SPAM..... You are receiving this information it because we believe it should be of interest to you, your associates, colleagues.

Since many of your missed the www.futurecitychicago.org competition let me extend an invitation to join us next year !

For now here the results of the 2010 Chicago Regional Finals

Sincerely,
Robert B. Johnson
SEAOI
134 N. LaSalle Suite 1910
Chicago, IL 60602
tel: 312-726-4165 x200
e-mail: office@seaoi.org

volunteer to www.futurecitychicago.org AND

volunteer to IIT-EWEEK / Rice Campus -Dupage

(now four weeks away)

<http://www.dupageeweek.iit.edu/>

Check it out

=====

FOR IMMEDIATE RELEASE:

CONTACT: Don Wittmer, Regional Coordinator/ 312.930.9119

Rick Gomes, Sayles & Winnikoff Communications/ 212.725.5200 x114

**ST. PAUL OF THE CROSS SCHOOL WINS CHICAGO REGIONAL
FUTURE CITY[®] COMPETITION**

**CHAMPIONSHIP TEAM NOW HEADS TO FINALS IN
WASHINGTON DC, FEBRUARY 13-17**

CHICAGO, January 18, 2010 – A team of students from St. Paul of the Cross School (Park Ridge, IL) has won the Chicago Regional National Engineers Week Future City[®] competition. They will now travel to Washington DC to compete in the 18th Annual Future City National Finals (www.futurecity.org), scheduled for February 13-17, 2010 at the Hyatt Regency Capitol Hill. More than 33,000 students from 1,100 middle schools in 39 regions across the country are participating in the Future City regional competitions. The grand prize is a trip to Space Camp in Alabama, provided by National Finals host Bentley Systems, Incorporated, the leading company dedicated to providing comprehensive software solutions for the infrastructure that sustains our world.

The three winning team members were, Christopher Gloeckle, Caroline Zimmermann, and Ben Paoelli, who collaborated with students Sam Anderson, Erich Kohberger, Rachel Maurer, Meghan McErlean, Theresa Rathslag, Michelle Sisco, Joseph Swoboda, Mary Vozenelik, Jack Whalen and Lauren Whalen. The teachers for the winning team were Christine Stypka and

Laurie Moran and their volunteer engineer mentors were John Zimmermann of Terra Consulting Group and Philip Spagnolo of Spagnolo Enterprises, Ltd.

3rd Time the Charm

In 2008, a team from St. Paul of the Cross School came in 4th place. In 2009, a team from St Paul of the Cross came in 3rd place. In 2010, they took away top honors! Celedon is the name for the new city established on the shores of eastern Australia. Celedon is a futuristic paradise located in Western Australia in the year 2170. Centuries ago it was the surfing capital of the world with an economy driven by extensive coal mines near the city. After the coal supplies were exhausted, the surfer-miners left the city leaving an environmental disaster behind. Sustainable housing domes led the recovery of Celedon. The early homes were 25' diameter domes designed for a family of four. The 2-bedroom, 2-bath homes were inexpensive to construct, made completely of sustainable materials, and incorporated innovative ways to capture and reuse rainwater, recycle waste, and harness the power of the sun and wind. The extensive public transportation systems of Celedon have eliminated the need for the automobile, and the city boasts many pleasant attractions such as parks, playgrounds, sports fields, zoos and a convention center. The city even constructed a replica of Chicago's John Hancock Building so Celedonians could enjoy the city and attract tourists. Residents of Celedon are provided the best health, safety and welfare available, and have the highest education level in Australia. The city is still looking to the future, planning vertical farms, tidal energy generators, and a carbon-free transportation system.

Christopher Gloekle (age 14) says, "I learned that it takes a lot of planning to create a green and sustainable living environment. I think that even though it's hard work to become an engineer I will still aspire to become one".

Ben Paoletti (age 12) comments, "I didn't know there were so many types of engineers".

The REAL FUTURE

"This program has been instituted by the engineering profession to bring hands-on, practical applications of mathematics and science to educate young minds as to the essential role engineers play in creating our modern technological society," replied Robert B. Johnson, Bowman, Barrett & Associates, a spokesman for the Chicagoland Future City Program. "The future of America is not found on the basketball courts, football grid irons, tennis courts, golf courses or baseball diamonds, but in the minds of these young dreamers."

Chicago runners up include:

- Second place school: St. Clair RXIII, St. Clair, MO
- Third place school: Franklin Middle School, Wheaton, IL
- Fourth place school: St Paul's Lutheran School, Brookfield, IL
- Fifth place school: Mount Carmel Academy, Chicago, IL

About the Competition

On January 16th students met at the University of Illinois - Chicago Circle Campus to exhibit their models. More than 40 professional engineers queried the teams as to the merits of their designs. Another 50 architects-engineers were involved in the special award judging. Entries were judged on creativity, city layout, and attractiveness by a variety of judges from the private and public sectors of engineering. This year was the 18th year for what has become an annual event for Chicago's engineering community. The Chicagoland engineering community is proud of their record as the only city to host the competition since its inception in 1992.

Students create cities on computers using the *SimCity™ 4 Deluxe* software, provided by Electronic Arts, and then build three-dimensional, tabletop models to scale. To ensure a level playing field, models must use recycled materials and can cost no more than \$100 to build. Students must present and defend their designs at the competition before a panel of engineer judges who test the depth of the teams' knowledge. Students also write a 300-500 word city narrative describing their city and a 700-1000 word essay on the topic "Providing an Affordable Living Space for People Who Have Lost Their Home Due to a Disaster or Financial Emergency."

This year's final round judges in Chicago included:

- Frank Avila, Commissioner – Water Reclamation District of Greater Chicago
- Rupert Graham, Superintendent of Highways – Cook County Highway Department
- Betty Shanahan, Executive Director – Society of Women Engineers
- Randall Blankenhorn, Executive Director – Chicago Metropolitan Agency for Planning
- Kay Whitlock, Vice President of CBBEL & past president of the American Society of Civil Engineers –Illinois Section

Special awards were present to schools for their individual accomplishments in the competition. In addition to winning the top prize, the St. Paul of the Cross team received additional honors from The Chicago Committee on High-Rise Building (www.cchr.org) for their city that demonstrated the best use of skyscrapers in their design and captured an award from the Structural Engineers Association of Illinois (www.seai.org) for the best creative use of materials, concepts and construction techniques of structures in their model. The Institute of Transportation Engineers (www.iite.org) presented Immaculate Conception Grade School, Chicago a special award for excellence in transportation safety and operations. All together 31 "Special Awards" were presented to teams. Even Chicago architects joined in presenting another award to the students from St. Paul of the Cross, Park Ridge with the "Most Livable Community" award from the Chicago Chapter of the American Institute of Architects. The students voted for an award too! Franklin Middle School received the peer award for the Best Model as selected by the students. The best computer model went to the team from Chicago State University.

Derek Johnson, co-coordinator offers this comment, "It is a great experience for all involved -- the students have fun while learning about engineering and gaining valuable teamwork and presentation skills. Engineers, mentors, judges and volunteers always leave impressed by the students' ability and enthusiasm."

Regional chairman Don Wittmer notes, "It is exciting to see the interaction between the students and witness the enthusiasm that these students have in learning about engineering and the real life problems that are encountered everyday. Our hope is that this competition helps students consider the possibility of studying engineering when they attend college." In fact one of the engineer judges, Denise Garcia was a student in the competition way back in 1995. Now she is an engineer!

Caroline Zimmerman (age 13) declares, "I learned that engineers play a big role in the production of a city."

All participants in the regional competition received promotional items including, participation medallions, E-Week Tee-Shirts, Future City Water Bottles and a host of other trinkets. These gifts were courtesy of HNTB, ASCE-Illinois Section and other sponsoring societies and companies. The winning teams will be feted at the Chicagoland Engineers Week Benefit, February 19th.

For the National Competition the grand prize of a trip to Space Camp in Huntsville, Alabama, the second place team receives a \$2,000 scholarship from the National Society of Professional Engineers (NSPE) for its school's technology program. Third place receives a \$1,000 scholarship from the Institute of Electrical and Electronics Engineers (IEEE) for that school's technology program. The 18th Annual Future City Competition for seventh and eighth grade students is sponsored in part by the National Engineers Week Foundation, a consortium of professional and technical societies and major U.S. corporations. While Bentley Systems,

Incorporated supports the national finals, Shell is a major sponsor for many of the regional competitions.

About Engineers Week

The National Engineers Week Foundation, a formal coalition of more than 100 professional societies, major corporations and government agencies, is dedicated to ensuring a diverse and well-educated future engineering workforce by increasing understanding of and interest in engineering and technology careers among young students and by promoting pre-college literacy in math and science. Engineers Week (February 14-20, 2010) also raises public understanding and appreciation of engineers' contributions to society. Founded in 1951, it is among the oldest of America's professional outreach efforts. Co-chairs for 2010 are ExxonMobil Corporation and the American Society of Civil Engineers. For more information, visit www.eweek.org.

For those wishing to compete in next year's competition or has any questions, please contact Don Wittmer at [dwittmer@hntb.com](mailto:d Wittmer@hntb.com) or (312) 930-9119 or visit the website www.futurecitychicago.org.

#

SimCity 4 Deluxe™ is a trademark of Maxis, Walnut Creek, California and a wholly owned subsidiary of Electronic Arts. National Engineers Week, is a registered trademark of the National Society of Professional Engineers.

Editors note: Photographs of the students models are available upon request.

For a video of the 2010 Program see:

<http://news.medill.northwestern.edu/chicago/news.aspx?id=153924>

For a video of the 2009 event see: <http://www.youtube.com/watch?v=vRY3pnR-SwQ>

For sample pictures from prior years:

<http://www.futurecitychicago.org/pictures.htm>

<http://www.flickr.com/photos/10752828@N05/sets/72157614572357964/>

2008 PR and Video!

<http://news.medill.northwestern.edu/chicago/news.aspx?id=76389>

Additionally

The Future City competition is one of the elements for the recognition of NATIONAL ENGINEERS WEEKr... Since 1951, NATIONAL ENGINEERS WEEKr, has been the nationwide celebration of the engineering profession, to acknowledge the essential role which engineering has played in advancing civilization and adding quality to our lives. In Chicago, activities scheduled include engineering lectures, student outreach efforts, bridge building competitions and exhibitions of engineering achievements.

Contact: Tim Seedan - Western Society of Engineers at tim@wsechicago.org or at 630/ 724-9770, 241-0142 fax. For Engineers Week -Illinois details or visit the Chicagoland EWEEK website www.chicagolandeweek.org

For additional information about Illinois Engineers Week

Visit the National Engineers Weekr WEBSITE at <http://www.eweek.org> or

Illinois Engineers Week information at <http://www.chicagolandeweek.org>

Additional information on the Future City Competition can be found at www.futurecity.org

PICTURES

Winning Team from St Paul of the Cross School (Park Ridge)



2nd Place ST. Clair RXIII

There came all the way from Missouri to compete !



3rd place Franklin Middle School -Wheaton





Student presentation before a panel of judges





Students from Mt Carmel explaining their design during the Preliminary Round Judging.

Mr. Weiss,

Please share this email with the appropriate person, thanks.

The unsolicited proposal entitled “Protecting Lives and Municipalities during a Lahar” was revised to address the concerns voiced by Mr. William E. Scott, Geologist from the David A. Johnston Cascades Volcano Observatory. This document was renamed to “Protecting Lives and Municipalities in Washington State during a Lahar”; I find that this document’s title now better suited for its purpose.

The purpose of this document is to describe a proposed system that is to be connected to the Carbon River, the North and South Puyallup Rivers, and the Nisqually River, which will serve as the path for lahars as it travels, under its own power, to an uninhabited space.

The purpose of this system is to divert lahars, such that the municipalities near the Carbon River (Carbonado, Wilkeson), those near the Puyallup River (Fife, Orting, Puyallup, Sumner and Tacoma) and those near the Nisqually River (Ashford, Elbe) do not become inundated from lahars in the event Mount Rainier erupts.

Please consider the following:

- Like Mount Rainier, Nevado del Ruiz in Colombia had glacial caps and a long history of lahar activity. On September 13, 1985, Nevado del Ruiz released a lahar triggered by a small eruption the previous day. This lahar traveled down the Azufrado River valley and buried the town of Armero and approximately 24,000 of its residence before they knew what was happening. Some volcanologists have predicted that Mount Rainier will be the site of the next catastrophic lahar event; such an event threatens the lives more than 300,000 persons that live within this region of Washington State.
- According to a 2000 census, the City of Fife had a population of 4,784. If the City of Fife was completely inundated by a lahar, the cost of reconstruction may possibly be \$12.60 billion.

- According to the City of Orting, this municipality has a population of about 6,075. If the City of Orting was completely inundated by a lahar, the cost of reconstruction may possibly be \$6.08 billion.
- According to a 2000 census, the City of Puyallup had a population of 33,011. If the City of Puyallup was completely inundated by a lahar, the cost of reconstruction may possibly be \$27.23 billion.
- According to a 2000 census, the City of Sumner had a population of 8,504. If the City of Sumner was completely inundated by a lahar, the cost of reconstruction may possibly be \$15.08 billion.
- The Port of Tacoma is the seventh largest container port in North America, which handles more than \$36 billion in annual trade. For the year of 2008, the Port of Tacoma had a value of foreign trade totaling \$35.37 billion and a value of domestic trade totaling \$3.5 billion.

The Puyallup Tribe of Indians would benefit from the proposed system, because it will prevent the area of this tribe from becoming inundated by a lahar.

To review the lahar risk that will be produced by an eruption of Mount Rainier, please review the following web-pages:

<http://en.wikipedia.org/wiki/Lahar>

<http://pubs.usgs.gov/fs/2008/3062/fs2008-3062.pdf>

Is there an interest by this branch of the US government to review the titled document, such that this division will come to know the proposed system? If so, please send me an email requesting this document; please also provide the recipient's name, the recipient's position, the recipient's mailing address, the recipient's email address and the recipient's phone number. This document will be emailed.

I would like to thank you for considering the contents of this email.

Genuinely,

Timothy M. Young

Email: timothyoung@hotmail.com

(The attached file is a one page announcement/description of this unprecedented STEM outreach event).

Knoxville News-Sentinel < <http://www.knoxnews.com/news/2010/jan/15/teachers-visit-workplaces/> >

Teachers to visit workplaces

Program aims to help students see math, science usefulness

By Lola Alapo

Friday, January 15, 2010

Knox County math and science teachers, in an effort to make their subject matter more relevant to their students, will themselves shadow professionals in the science, technology, engineering and mathematics field one day next month.

The exposure will allow them to show students how the classroom experience can be applied in the real world, school and business leaders said.

School system officials and the Knoxville Chamber are seeking area STEM businesses to host the 500 middle and high school teachers for the Feb. 15 in-service day.

A criticism of Tennessee curriculum is that while it has rigor, making it relevant to students' lives has been somewhat lacking, said Becky Ashe, Knox County Schools director of curriculum and instruction.

"We want teachers to be able to help kids see options for employment in the future," she said.

She added that many teachers went from a bachelor's program to a master's in education, so while they may know their course content, they "may not have worked in the field the kids are interested in."

To date, 242 teachers have been placed, with 258 still in need of a host company, Ashe said. Companies may choose one of two half-day slots, 8:30-11:30 a.m. or 1:30-4:30 p.m.

Later that day, teachers will return to their buildings to debrief about "things they saw, connections they made and ... how do we get those into lesson plans," she said.

The Feb. 15 program is being led by Vols4STEM < www.Vols4STEM.org >, a partnership between several area organizations, including the Tennessee Society of Professional Engineers, the school system and the Knoxville Chamber.

Much of the work force and economic growth in East Tennessee is happening in the STEM areas, so “we’ve got to make sure we have a work force that’s going to be ready to take those jobs,” said Jennifer Evans, the chamber’s director of work force development and education.

Teachers inspiring students to pursue those areas is key, she said.

The in-service day also is an opportunity for business professionals to become directly involved in education, said Robert Campbell, vice president of Robert Campbell Associates, a consulting firm specializing in civil engineering and surveying. The company will be hosting 10 teachers.

“What this does is put a face on an extra resource for (teachers),” he said.

For more information on participating, contact Ahnna Estes at aestes@knoxvillechamber.com or 865-246-2658.

Lola Alapo may be reached at 865-342-6376.

Vols4STEM is a resource of the Innovation Valley* intended to facilitate the voluntary collaboration of its Science, Technology, Engineering, and Math (STEM) professional community, STEM employers, STEM educators, and other stakeholders. Vols4STEM was conceived as a means to improve K-12 STEM education and workforce development, by engaging more STEM professionals as volunteers in STEM outreach activities to area youth. Vols4STEM partners connect volunteers with educators and students to work on classroom activities and STEM clubs together, and provide muchneeded resources, supplies, and expertise to area classrooms.

The largest Vols4STEM initiative to date is a plan to place all 500 middle and high school math and science teachers in Knox County at area STEM companies for their February system wide in-service. This will provide educators with the opportunity to learn directly from area STEM professionals about how the concepts being taught in the classroom are applied in the workplace.

Teachers will shadow and learn from professionals in the field, and hopefully form an ongoing relationship with them to provide mentoring and support in the future.

Vols4STEM was formed in 2008 as an effort among several area organizations and individuals representing a three-legged stool of education, business, and STEM societies. Current partners include the Knoxville Chamber, Tennessee Society of Professional Engineers, American Society of Civil Engineers, Knox County Schools, Oak Ridge Economic Partnership, and Innovation Valley

Inc. Information about ongoing and proposed STEM outreach activities, opportunities to sign up as a volunteer, and other information are available online at: www.vols4STEM.org.

For more information, please contact Jennifer Evans, Director of Workforce Development & Education at the Knoxville Chamber and Chair of the Vols4STEM Steering Committee, at jevans@knoxvillechamber.com or (865) 246-2641.

*Greater Knoxville, Tennessee area which includes Knox County, Oak Ridge, Blount County, Loudon County and Roane County

Hello Deborah,

To follow up on a brief conversation we had a few weeks ago (sorry for delay, happy New Year!), I'm an American living in the United Arab Emirates. In 2007 I created a non-profit to empower education in science, technology and engineering for youth in the Middle East. Our largest benefactor to date has been the Foundation created by Royal/Ruling Family (Sheikh Mohammed bin Zayed Al Nahayan) of Abu Dhabi, the oil rich capital of UAE.

We have an educational working relationship with NASA (with blessing of US Dept. of State), timing of which is beautiful as it provides high profile support of President Obama's 'mandate' to improve science and tech development in the Muslim world.

<http://www.thenational.ae/apps/pbcs.dll/article?AID=/20091206/NATIONAL/712059855>

<http://www.en.mideast.ru/336/41492>

<http://www.google.com/search?hl=en&source=hp&q=NASA+Arab+Youth&btnG=Google+Search&aq=f&oq=&aqi=>

I am interested to meet you and share what we've got brewing here. I'd also like to begin sharing ideas for tech transfer in the future --our NASA projects and other innovative, STEAM (we add an "A" for Aerospace) related contests, programs would prove quite unique and compelling for the educational realm in USA at some point -- and fits also with the President's innovation agenda for education... As an American founding such programs-- and some in which we are poised to obtain US Gov't support, I believe that transfer of this know-how and our IP could be shared 'back home' for the benefit of 'our' kids... :)

Please let me know if you are able to meet me while I am in town. I also welcome participation by others you may deem have interest in this area. I have left VMs for Patricia McLaughlin, Stephen Markowitz and Kimberly Brickman.

Thank you kindly,

Lisa

D.C. Cell (not on until 16 Jan. although you can leave a V.M. if you like) 202-579-2574

Lisa LaBonté, CEO
Arab Youth Venture Foundation, FZE

Al Hamra, Al Jazeera

Rakeen Building, 2FL

P.O. Box 13338, RAK

UAE - Dubai Satellite:

Tel +971-4-344-8603

Fax +971-4-344-8602

Mob. +971-50-888-4005

Dr. Stine,

I wanted to share some details on our program, USAGraduate.com, and see if it would be possible to setup a meeting to showcase our program to your office. I feel it has the potential to duplicate our success in New York State, throughout the country, and become a very successful program with the President's Educate to Innovate initiative.

USAGraduate.com creates pathways for future science and technology entrepreneurs while responding to the growing demand for professionals with Science, Technology, Engineering, and Math (STEM) backgrounds. In addition, with the emerging emphasis on green technologies, the need for STEM knowledge will continue to expand because sustainable solutions require the skills and expertise of STEM professionals. Responding to the concern of government and industry about meeting the demand for science and technology professionals, our program has already helped more than 25,000 students in the Syracuse area.

Overview Document: <http://www.usagraduate.com/marketing/overview.pdf>

Student Presentation:

<http://www.usagraduate.com/student%20introduction/Student%20Introduction.mp4>

Local Article: <http://www.usagraduate.com/marketing/article.pdf>

Sincerely,
Bob Clary

--

Bob Clary
Executive Director
USAGraduate.com
318 South Clinton Street, Suite 501
Syracuse, New York 13202
315.560.5639
Skype: bob_clary

To Members of PCAST Thank you for allowing me to attend the full session of PCAST yesterday. It was clear from members comments and choice of speakers that science, science education and health care delivery founded in science based data are major themes for PCAST. Congressional mandates which force health care delivery to include delivery of non-evidenced (non-science) based medicine stand in direct opposition to the science education themes which members voiced. The themes are linked and current dichotomy is clear. On the one hand PCAST will ask for our educational system to embrace the best. On the other hand scientists are ignoring the challenge and turning a blind eye to health care delivery which has no foundation in scientific fact or theory.

Eugenie Mielczarek
Emeritus Professor of Physics
703.993.1282

Hello,

Today I have seen on internet of your site a very exciting speech of Hon. President Obama about the education of Maths and Science. No doubt in his speech I was impressed and what impotence is for the teachers as regards to maths and science subjects.

In the mean I am Mr. Vinayak M Barve Age. 61 yrs. from India. in profession a Engineer.

We are working in computers base training for mass education for last 15 years.

We have developed one paperless Mathematical Notepad for practice for the students all around the world. The basic intension is to develop the interest in maths on computer it self. No need of any paper, tool box. Only with the program he / she can make the practice of their own.

The program is available in USA with my friend

Jetser Carasco

Certified math teacher

darser01@hotmail.com

123 Blue Hills pkwy, Milton, Ma. 02186

I will be happy if you allow him to give a demo of the same Interactive Mathematical Notepad which is useful for the students. Let me inform please.

With regards,

Sincerely,

Vinayak M Barve

vinayakba@gmail.com

09222093864 (India)

Attention OSTP

I've been reading the initiatives by Obama Administration to more training for Math, STEM teacher

but then hold-on

I think you might find the performance of American student is NOT as bad as one might think!

How come we see, read her little of the various engineering outreach programs??

We've begun the final push to promote Future City - Chicago

here's the latest PR

Bob Johnson

312-228-0100

volunteer to www.futurecitychicago.org

volunteer to IIT-EWEEK / Rice Campus -Dupage

check this out:

<http://www.dupageeweek.iit.edu/>

AND THESE PICTURES!

<http://www.flickr.com/photos/41494787@N03/>

<http://www.seaoi.org/futurecity.htm>

<http://www.lynnbecker.com/repeat/calendar/current/current.htm#16>

<http://www.sciencechicago.com/civCRM/event/info?reset=1&id=18639&topic=>

Robert B. Johnson, SE, PE

Senior Engineer

(312) 228-0100 (voice)

***** DISCLAIMER *****

This transmission is for the designated recipient only and may contain privileged, proprietary, or otherwise private information. If you are not the intended recipient, any dissemination, distribution or copying is strictly prohibited. If you have received this e-mail in error, please notify the sender by replying to this message and delete this e-mail. Thank You.

***** END DISCLAIMER *****

From: Rick Gomes [mailto:rick@sayleswinnikoff.com]

Sent: Tuesday, January 05, 2010 11:11 AM

To: 'Rick Gomes'

Subject: PRESS RELEASE - Chicagoland Middle Schoolers Compete to Create Best Green Spaces to House Neediest in Future City Comp, Jan 16 at Univ of Illinois at Chicago

Chicagoland's Middle School Students Vie for National Recognition in Annual Future City Competition Regional Finals on January 16, 2010 at University of Illinois at Chicago

This Year's Theme is Green Living –

Students Are Asked to Create Spaces to House the Neediest

CHICAGO, December 28, 2009 – What do engineering, economics, math and the environment have in common? They're all topics middle schoolers from nearly 40 regions across the U.S. are tackling in the 2009-2010 **National Engineers Week Future City® Competition**. This year's theme is "Providing an Affordable Living Space for People Who Have Lost Their Home Due to a Disaster or Financial Emergency."

Students have been working on their Future City projects since they returned to school in the fall, and now each region is preparing for January's regional finals. First-place winners from each qualifying regional competition receive a trip to the 18th annual Future City National Finals in Washington, D.C., February 13-17, 2010 during National Engineers Week. National grand prize is a trip to U.S. Space Camp in Huntsville, Alabama. More than 33,000 students from 1,100 middle schools are expected to participate nationwide. **In the Chicago Region, the Future City Competition regional finals will be held on January 16, 2010 at University of Illinois at Chicago, Student Center East.**

Sponsored by the nation's professional engineering community, Future City aims to stir interest in science, technology, engineering and math among young people. Future City is the nation's largest engineering education program and among the most popular.

Students work in teams under the guidance of a teacher and a volunteer engineer mentor to design and build a city of tomorrow. They create cities on computers using the *SimCity™ 4 Deluxe* software and then build three-dimensional, tabletop models to scale. To ensure a level playing field, models must use recycled materials and can cost no more than \$100 to build. Students write brief narratives describing their city and must present and defend their designs at the competition before a panel of engineer judges who test the depth of the teams' knowledge. They must also write and conduct research for an essay of 700-1,000 words on "Providing an Affordable Living Space for People Who Have Lost Their Home Due to a Disaster or Financial Emergency."

Participants are asked to consider the social, economic and ecological impact of the manufacturing and construction techniques they design. The design should be constructed with the ideal of providing affordable homes to those facing disaster or financial crisis, and earning only 50%-80% of the median income of the surrounding city. The living space needs to use sustainable materials, have a low-carbon emissions footprint, and achieve the “Green Ideals” of energy efficient building.

“Our students are enthusiastic, focused and highly motivated,” says Don Wittmer, Regional Coordinator. “They have a unique appreciation for this theme because they understand that it addresses some of the most pressing issues our society faces. Their work reflects the passion they feel and their commitment to trying to make the world a better place.”

For more information on judging or mentoring in the Future City Competition, visit www.futurecity.org, <http://www.futurecitychicago.org> or contact Don Wittmer at 312.930.9119 or Garth Daley at 773.380.9239.

#

About Engineers Week

The National Engineers Week Foundation, a formal coalition of more than 100 professional societies, major corporations and government agencies, is dedicated to ensuring a diverse and well-educated future engineering workforce by increasing understanding of and interest in engineering and technology careers among young students and by promoting pre-college literacy in math and science. Engineers Week also raises public understanding and appreciation of engineers' contributions to society. Founded in 1951, it is among the oldest of America's professional outreach efforts. Co-chairs for 2010 are ExxonMobil Corporation and the American Society of Civil Engineers. For more information, visit www.eweek.org.

CONTACT:

Chicago Region:

Don Wittmer/Regional Coordinator

312.930.9119

dwittmer@hntb.com

Garth Daley

773.380.9239

gdaley@CRAworld.com

Sayles & Winnikoff Communications:

Rick Gomes

212.725.5200 x114

rick@sayleswinnikoff.com

Rick Gomes

Senior VP

Sayles & Winnikoff Communications

1201 Broadway, Suite 904

New York, NY 10001

212.725.5200 x114

917.783.5228 (c)

212.679.7368 (f)

rick@sayleswinnikoff.com

 Go Green! Print this email only when necessary. Thank you for helping Sayles & Winnikoff Communications be environmentally responsible.

n Chicago contact:

Don Wittmer

(312) 930-9119

dwittmer@hntb.com <<mailto:dwittmer@hntb.com>>

www.futurecitychicago.org

<<http://www.futurecitychicago.org/>>

Check out the new feature !!! A map locating the
participating schools!

Supplemental resources:

For information on the Chicago winners see photos and additional info @ www.futurecitychicago.org
<<http://www.futurecitychicago.org>>

Check this video: <http://www..youtube.com/watch?v=vRY3pnR-SwQ>

2009 Pictures: <http://www.flickr.com/photos/10752828@N05/sets/72157614572357964/>
<<http://www.flickr.com/photos/10752828@N05/sets/72157614572357964/>>

2009 EWEEK Photos <http://www.flickr.com/photos/10752828@N05/sets/72157614567197278/>

2009 Future City Finals: <http://www..youtube.com/watch?v=YK73OIn3zGk>

2008 Story and video <http://news.medill.northwestern.edu/chicago/news.aspx?id=76389>
<<http://news.medill.northwestern.edu/chicago/news.aspx?id=76389>>

And for [2008] pictures: <http://www.flickr.com/photos/10752828@N05/sets/72157603878323166>

2008 EWEEK Photos (Including Future City)

<http://www.flickr.com/photos/10752828@N05/sets/72157604569050537>
<<http://www.flickr.com/photos/10752828@N05/sets/72157604569050537>>

additional information

<http://www.todaysengineer.org/2008/Mar/FCC.asp> <<http://www.todaysengineer.org/2008/Mar/FCC.asp>>

http://www.tiesmagazine.org/archives/mar_2003/pdf/mar_2003_FutureCities.pdf

<http://www.organicgreenandnatural.com/2009/08/19/middle-school-students-to-design-affordable-housing-in-future-city-competition/> <<http://www.organicgreenandnatural.com/2009/08/19/middle-school-students-to-design-affordable-housing-in-future-city-competition/>>

<http://bdpa.groupsie.com/discussion/topic/show/223796>
<<http://bdpa.groupsie.com/discussion/topic/show/223796>>

TV

Interview with 2008 Team

<http://video.google.com/videosearch?q=St.+Paul+of+the+Cross+-+Future+City+Competition&emb=0&aq=f>
<<http://video.google.com/videosearch?q=St.+Paul+of+the+Cross+-+Future+City+Competition&emb=0&aq=f>> #

SimCity 4 deluxe TM is a trademark of Maxis, Walnut, California.

National Engineers Week is a registered trademark of the National Society of Professional Engineers

"Scientists discover the world that exists; engineers create the world that never was."
— Theodore von Karman

This quote by (engineer) Theodore von Karman says a lot about engineers. Engineers are creative, pay attention to detail, and use math and science

\\EWEK10\Futurecity\FutreCity-Loc.SAM

This transmission is for the designated recipient only and may contain privileged, proprietary, or otherwise private information. If you are not the intended recipient, any dissemination, distribution or copying is strictly prohibited. If you have received this e-mail in error, please notify the sender by replying to this message and delete this e-mail. Thank you.

=====

2009 Winning team -

Washburne Middle School - Winnetka



Take NOTE ALL Girls !

2nd Place Chicago State University



That tall Structure

**above is a "VERTICAL
FARM"**

3rd Place-- St Paul of the Cross - [Park Ridge](#)



Close-up of one of the models



Finalists are required to present their design, explain their city before a panel of judges and in front of an audience



Hope to see you in January - 2010 at the University of Illinois- Chicago



Chicago Television News Departments will be there to film / record the event!!

*Will you be
attending????*

dear DR\STINE

it is truly an honor writing to you and to the PCAST

my name is ihab I am from Egypt and I reached a novel medical and scientific approach and concept concerning the treatment and prevention of many medical conditions like HIV , CANCERS, among other conditions.

the idea is now an application registered at the US PATENT AND TRADEMARK OFFICE this new concept is applicable and based on sound scientific basis and if given due care it will be a major step and a tremendous achievement to MEDICINE AND HUMANITY.

I am proudly present my idea to America to this great nation that considers science as the most effective and crucial tool to reach Nobel goals and to survive

all what I am asking is a chance for my idea to be developed into a real medical therapeutics to help patients allover the world suffering from these devastating diseases as aids ,cancer and TB

please find an attached copy of the idea manuscript and I am confident that when your most esteemed scientists read this idea they will recognize the great importance and depth of this novel concept.

thanks

best regards

DR/ IHAB MAMDOUH ISHAK SADEK

PATENT 19698

- 1 -

DELIVERY OF RESTRICTION ENDONUCLEASES TO TREAT HIV, CANCER, AND OTHER MEDICAL CONDITIONS BACKGROUND

Cells can contain undesired polynucleotide sequences, either due to abnormalities in their genetic material, which can lead to cancer, or through infection with a virus. According to the World Health Organization, cancer causes about 13% of all human deaths. (WHO, 2006). Once diagnosed, cancer is usually treated with a combination of surgery, chemotherapy and radiotherapy. Complete removal of the cancer can sometimes be accomplished by surgery, but the propensity of cancers to invade adjacent tissue or to spread to distant sites by microscopic metastasis often limits its effectiveness. The effectiveness of chemotherapy is often limited by toxicity to other tissues in the body. Radiation can also cause damage to normal tissue.

Viruses can cause many common human diseases, including the common cold, influenza, chickenpox and cold sores. Many serious diseases such as ebola, AIDS, avian influenza and SARS are caused by viruses. A virus can have either a DNA or RNA genome. Retroviruses, which contain RNA genomes, use the reverse transcriptase enzyme to convert RNA into DNA and often integrate their DNA into the host DNA genome. An example of a retrovirus is Human Immunodeficiency Virus (HIV). Antiviral treatments include those that target different stages of the viral life cycle. However, treatment with antiviral drugs has drawbacks, including that viruses may develop drug resistance over time and become less susceptible to treatment.

Prokaryotic cells have been known to contain endonucleolytic restriction enzymes (Gingras, 1991, *Modern Microbial Genetics* 301-321 (Wiley-Liss, Inc.)). The restriction endonucleases recognize a specific sequence in viral DNA and subsequently cleaves both strands of the DNA into fragments, which are then degraded further by other endonucleases. Restriction endonucleases have not been found pervasively in eukaryotic cells, although restriction endonucleases have been isolated from several eukaryotic sources. (Sklar et al., 1986, *J. Biol. Chem.* 261: 6806-6810; Lao et al., 1986, *Sci. Sin. (Series B)* 29: 947-953).

PATENT 19698

- 2 -

One reported study (Kwoh et al., 1986, *Proc. Natl. Acad. Sci. USA* 83: 7713) unsuccessfully attempted to utilize restriction endonucleases expressed by eukaryotic cells to inhibit viral infection. U.S. Patent No. 5,523,232 to Sechler further proposed treating various conditions by administering restriction endonucleases to a subject. In another study of the effect of endonuclease activity, mutant mitochondrial DNA was eliminated in cybrid cells through the transient expression of the endonuclease SmaI (Tanaka et al., *Journal of Biomedical Science*, 2002, 9: 534-541).

SUMMARY

The present invention relates to treating a medical condition in a subject in which the medical condition is caused by the presence of an undesired DNA sequence in a predetermined cell type. The method treats the subject with the medical condition by administering to the subject a one or more restriction endonucleases to specifically cleave the undesired polynucleotide.

The present method provides for the treatment of a medical condition characterized by the presence of an undesired DNA sequence in a predetermined cell type. Such conditions include viral infections such as HIV, bacterial infections, cancer, and genetic disorders involving the accumulation of undesired proteins within the cells of a subject. The method comprises the steps of (a) providing a viral vector comprising a restriction endonuclease or one or more polynucleotides coding for the restriction endonuclease; and administering to a subject an amount of the vector capable of treating the medical condition, wherein the restriction endonuclease specifically cleaves the undesired DNA sequence.

The vector preferably is targeted to cell type in which the endonuclease is needed, and also preferably delivers the restriction endonuclease protein directly. Such vectors can be, for example, a virus or viral shell derived from HCMV or AAV, to which the endonuclease may be fused. The endonuclease can alternatively be fused to a protein transduction domain transporter peptide in order to effect entry of the endonuclease into a cell. Alternatively, the vector can deliver a polynucleotide able to be translated within a

PATENT 19698
- 3 -

host cell in order to create a restriction endonuclease within the host cell. Such polynucleotides can be delivered as plasmids, such as with a liposome vector, or in a viral vector. The viral vector can be, e.g., a replication-defective HSV vector, an attenuated HSV vector, a baculovirus, or an alpha-virus. Vectors are preferably formulated with a pharmaceutically acceptable excipient prior to administration.

DESCRIPTION

Definitions

As used herein, the following terms and variations thereof have the meanings given below, unless a different meaning is clearly intended by the context in which such term is used.

The term “cancer” refers to a disease or disorder that is characterized by unregulated cell growth. Examples of cancer include, but are not limited to, carcinoma, lymphoma, blastoma and sarcoma. Examples of specific cancers include, but are not limited to, lung cancer, colon cancer, breast cancer, testicular cancer, stomach cancer, pancreatic cancer, ovarian cancer, liver cancer, bladder cancer, colorectal cancer, and prostate cancer. Additional cancers are well known to those of skill in the art.

“DNA sequence” refers to a chain of deoxyribonucleotides, i.e. oligonucleotides or polynucleotides, in either single- or double-stranded form.

“Expression” of a nucleotide sequence refers to the transcription of the sequence and its subsequent translation into a polypeptide.

“Genetic disorder” refers to a medical condition caused by abnormalities in a gene of a subject.

The term “mammal” is defined as an individual belonging to the class Mammalia and includes, without limitation, humans, domestic and farm animals, and zoo, sports, and pet animals, such as sheep, dogs, horses, cats and cows.

“Medical condition,” “disease,” and “disorder” refer to an abnormal condition of an organism that impairs one or more bodily functions and/or causes discomfort, generally associated with specific symptoms and/or other indications. The medical

PATENT 19698

- 4 -

conditions treated by the present method are due to the presence of an undesired polynucleotide in a host cell.

As used herein, the terms “nucleic acid,” “polynucleotide” and “nucleotide” refer to molecules consisting of or comprising one or more nucleic acids, whether such nucleic acids are composed of phosphodiester linkages or modified linkages such as phosphotriester, phosphoramidate, siloxane, carbonate, carboxymethylester, acetamidate, carbamate, thioether, bridged phosphoramidate, bridged methylene phosphonate, bridged phosphoramidate, bridged phosphoramidate, bridged methylene phosphonate, phosphorothioate, methylphosphonate, phosphorodithioate, bridged phosphorothioate or sulfone linkages, or combinations of such linkages. The terms nucleic acid, polynucleotide and nucleotide also specifically include molecules consisting or comprised of nucleic acids composed of bases other than the five biologically occurring bases (adenine, guanine, thymine, cytosine and uracil).

“Nucleotide sequence” refers to a chain of deoxyribonucleotides or ribonucleotides, i.e. oligonucleotides or polynucleotides, in either single- or doublestranded form.

The term “operably linked” refers to functionally related nucleic acid sequences.

When a promoter controls and/or enhances the transcription of a nucleotide sequence, for example, it is said to be operably linked to the nucleotide sequence.

“Promoter” refers to a nucleotide sequence or sequences, usually comprising a transcription factor binding site, which directs and/or enhances transcription of another nucleotide sequence.

A “replication defective” viruses and viral vectors are those which can transmit a polynucleotide or protein into a host cell in need of treatment with the present methods but which are unable to replicate independently in the host cell and produce progeny viruses. In some cases replication defective viruses can be replicated in a host cell with the aid of a helper virus. Replication defective virus particles (virions) generally contain all the viral structural components of the virus and can attach, penetrate, and release their nucleic acid within the host cell, but a mutation generally has destroyed an essential viral function such that new virions will not be made unless the missing function is otherwise
PATENT 19698

- 5 -

provided, such as by a helper virus. Replication defective viruses, such as those derived from HSV-2 and AAV, are known to those of skill in the art.

“Retroviruses” are viruses having an RNA genome. Retroviruses which can be treated according to the present invention are those that replicate in a host cell by producing DNA from an RNA genome, such as with the enzyme reverse transcriptase.

“Restriction endonuclease” or “restriction enzyme” refers to an enzyme that cuts double-stranded or single stranded DNA at specific recognition nucleotide sequences, or restriction sites. Restriction endonucleases can be prokaryotic or eukaryotic in origin. Restriction endonucleases can be naturally occurring restriction endonucleases, modified naturally occurring restriction endonucleases, artificial restriction endonucleases, or a combination of the foregoing.

“Subject” refers to an animal, preferably a mammal, and more preferably a human, in need of treatment and/or treated according to the methods described herein.

As used herein, "treatment" is a clinical intervention made in response to a disease, disorder or physiological condition caused by the presence of undesired polynucleotides manifested by a patient or to be prevented in a patient. The aim of treatment includes the alleviation and/or prevention of symptoms, as well as slowing, stopping or reversing the progression of a disease, disorder, or condition. "Treatment" refers both to therapeutic treatment as well as to prophylactic or preventative measures. Those in need of treatment include those already affected by a disease or disorder or an undesired physiological condition as well as those in which the disease or disorder or undesired physiological condition is to be prevented. "Treatment" need not completely eliminate a disease, nor need it completely prevent a subject from becoming afflicted with a disease or disorder.

"Tumor," as used herein, refers to all neoplastic cell growth and proliferation, whether malignant or benign, and all pre-cancerous and cancerous cells and tissues.

A "vector" is a polynucleotide, lipid, protein, and/or a virus or other collection of molecules, which is capable of transporting a protein such as a restriction endonuclease and/or a nucleotide sequence into a cell. Vectors can be, for example, plasmids, viruses, cosmids or phage. The vectors used in the present methods are preferably viral vectors, and more preferably are replication defective viral vectors. Viral vectors are derived
PATENT 19698

- 6 -

from viruses but contain an exogenous protein or polynucleotide in addition to or in place of the components normally comprising the virus. An "expression vector" is a vector that is capable of directing expression of a protein encoded by one or more genes carried by the vector when it is present in the appropriate environment.

As used herein, the term "comprise" and variations of the term, such as "comprising" and "comprises," are not intended to exclude other additives, components, integers or steps. The terms "a," "an," "the," and similar referents used herein are to be construed to cover both the singular and the plural unless their usage in context indicates otherwise.

Restriction Enzymes

It is contemplated that unmodified prokaryotic or eukaryotic restriction endonucleases can be used in the methods of the invention. A number of restriction endonucleases are known to those of skill in the art. A partial list of such endonucleases is provided in Table 1 below.

Table 1: Restriction Endonucleases

Enzyme Recognition Sequence Cut

EcoRI 5'GAATTC

3'CTTAAG

5'---G AATTC---3'

3'---CTTAA G---5'

EcoRII 5'CCWGG

3'GGWCC

5'--- CCWGG---3'

3'---GGWCC ---5'

BamHI 5'GGATCC

3'CCTAGG

5'---G GATCC---3'
3'---CCTAG G---5'
HindIII 5'AAGCTT
3'TTCGAA
5'---A AGCTT---3'
3'---TTCGA A---5'
TaqI 5'TCGA
3'AGCT
5'---T CGA---3'
3'---AGC T---5'
NotI 5'GCGGCCGC
3'CGCCGGCG
5'---GC GGCCGC---3'
3'---CGCCGG CG---5'
HinfI 5'GANTC
3'CTNAG
5'---G ANTC---3'
3'---CTNA G---5'
Sau3A 5'GATC 5'--- GATC---3'
PATENT 19698
- 7 -
3'CTAG 3'---CTAG ---5'
PovII 5'CAGCTG
3'GTCGAC
5'---CAG CTG---3'
3'---GTC GAC---5'
SmaI 5'CCCGGG
3'GGGCCC
5'---CCC GGG---3'
3'---GGG CCC---5'
HaeIII 5'GGCC
3'CCGG
5'---GG CC---3'
3'---CC GG---5'
HgaI 5'GACGC
3'CTGCG
5'---NN NN---3'
3'---NN NN---5'
AluI 5'AGCT
3'TCGA
5'---AG CT---3'
3'---TC GA---5'
EcoRV 5'GATATC
3'CTATAG
5'---GAT ATC---3'
3'---CTA TAG---5'

KpnI 5'GGTACC
 3'CCATGG
 5'---GGTAC C---3'
 3'---C CATGG---5'
 PstI 5'CTGCAG
 3'GACGTC
 5'---CTGCA G---3'
 3'---G ACGTC---5'
 SacI 5'GAGCTC
 3'CTCGAG
 5'---GAGCT C---3'
 3'---C TCGAG---5'
 SalI 5'GTCGAC
 3'CAGCTG
 5'---G TCGAC---3'
 3'---CAGCT G---5'
 ScaI 5'AGTACT
 3'TCATGA
 5'---AGT ACT---3'
 3'---TCA TGA---5'
 SphI 5'GCATGC
 3'CGTACG
 5'---G CATGC---3'
 3'---CGTAC G---5'
 StuI 5'AGGCCT
 3'TCCGGA
 5'---AGG CCT---3'
 3'---TCC GGA---5'
 XbaI 5'TCTAGA
 3'AGATCT
 5'---T CTAGA---3'
 3'---AGATC T---5'

Table 1 Notes: N = C or G or T or A; W = A or T

Patterns of restriction endonuclease cleavage in an undesired polynucleotide can be determined readily by computerized analysis once the nucleic acid sequence of the undesired polynucleotide has been determined. Thus, known restriction endonucleases that cut a polynucleotide in specific regions can be identified as candidates for use in the present methods.

PATENT 19698

- 8 -

In addition, restriction endonucleases used in the methods of the invention can also be modified forms of naturally occurring restriction endonucleases. Such modified restriction endonucleases can be produced by a variety of well-known techniques such as, for example, recombinant DNA techniques, conjugation to other moieties and carriers, and chemical modification. For example, it is possible to manipulate known restriction endonucleases to recognize different DNA sequences through random mutagenesis or

directed evolution (Lanio et al., 1998, *J. Mol. Bio.* 283: 59-69). Restriction endonucleases used in the methods of the invention include molecules that both preserve the cleavage activity of the natural enzyme as well as those that add additional structural features that provide properties desirable for removing undesired DNA from a target cell. Restriction endonucleases can also be created through random mutagenesis, based on an unwanted polynucleotide sequence which is to be cleaved. For example, mutagenized enzymes can be assayed in order to identify those with a desired nuclease activity, i.e. with a predetermined specificity for cleaving a nucleotide sequence in an unwanted strand of DNA. Techniques used in the design and selection of DNA-binding proteins or individual domains capable of novel sequence recognition make it possible to engineer restriction endonucleases to target specific DNA sequences (Segal and Barbas, 2000, *Current Opinion in Chem. Biol.* 4: 34-39).

In this way, restriction endonucleases can be custom made for removal of a particular undesired sequence of DNA present in a subject. In order to identify or design a custom restriction endonuclease that recognizes an undesired polynucleotide, a sample of the affected cells can be obtained by, for example, a biopsy of tumor cells. The DNA can then be extracted from the tumor cells and sequenced in order to obtain the sequence of an undesired polynucleotide to be excised.

A fragment of an enzyme that provides sequence recognition and endonucleolytic activities can also be used as the restriction endonuclease of the present methods, alone or combined with additional structural elements. For example, the active portion of a restriction enzyme can be combined with other substituents and/or moieties by means well known in the art to provide such additional functions as decreased immunological reactivity, receptor or antigen binding or other targeting moieties, and delayed release, among others.

PATENT 19698

- 9 -

Certain types of restriction endonucleases cleave substrate DNA outside their recognition sequences. Biochemical and structural studies have shown that these endonucleases consist of separate DNA recognition and cleavage domains. This uncoupling of substrate specificity and cleavage activity further allows for the creation of chimeric endonucleases of novel substrate specificity by fusing DNA cleavage domains to DNA recognition proteins or oligonucleotides. (Chan et al., 2007, *Nucleic Acids Research* 35: 6238-6248). Such chimeric restriction endonucleases can be used in the methods of the present invention.

The restriction endonucleases expressed in the present method are preferably selected to specifically cleave a sequence in an unwanted strand of DNA and not cleave sequences present in host DNA. In order to select an appropriate sequence in the unwanted strand of DNA to cleave, the sequence of the unwanted strand can be compared to the known sequences of the host cell in which the endonuclease is to be expressed, and a sequence in the unwanted DNA strand that is not present in the known host DNA can be selected. Preferably, the entire genome of a host cell is compared with the sequence of unwanted DNA in order to select an appropriate sequence to cleave. Once an affected cell is treated with a restriction endonuclease and the undesired polynucleotide excised according to the present methods, the ends of the host DNA are also preferably ligated together, resulting in a normal cellular DNA sequence.

Restriction endonucleases used in the methods of the invention can also be modified to alter structural features that affect their ability to enter a cell nucleus. For instance, restriction endonucleases within a particular range of molecular weights may be preferred for this purpose in the invention. Natural or engineered enzymes in the range of 60,000 daltons or above generally will not diffuse into the nucleus and therefore are preferred for applications in which the sequence to be cleaved by the restriction endonuclease is outside the nucleus of a cell, such as a DNA sequence of an intracellular bacteria such as mycobacterium tuberculosis. On the other hand, if it is desired that DNA within a cell nucleus be targeted, restriction endonucleases below 60,000 daltons are preferred. Active transport of restriction endonucleases into the nucleus can be achieved by adding a nuclear targeting sequences into the amino acid sequence of the restriction

PATENT 19698

- 10 -

endonuclease. Amino acid targeting sequences, such as those of various viral proteins, are known to the art.

PATENT 19698

- 11 -

Vectors and Vector Delivery

The restriction endonuclease of the present invention can be delivered as a protein to a predetermined cell type, or as a polynucleotide encoding the restriction endonuclease followed by expression of the polynucleotide. A vector as used in the present invention preferably will not adversely affect the host cell or produce viral proteins, and so will be able to evade the cell mediated immunity of the host. Additionally, the vector is preferably a replication defective viral vector.

Viral vectors are preferred for delivering restriction endonucleases to host cells in need thereof. Viral vectors can be used which transmit polynucleotides or proteins into a number of different cell types, such as AAV vectors. Many viral vectors however have the advantage of cell type specificity, i.e. being able to deliver restriction endonucleases to specific cell types which are implicated in a particular medical condition.

Vectors for treating HIV preferably target the cells that the HIV virus infects, i.e. CD4+ cells. Preferably, viral vectors for the treatment of HIV incorporate binding domains from HIV for the CD4+. In one embodiment, the vector can be a lentiviral vector. To obtain a replication defective lentiviral vector, several plasmids can be transfected into a packaging cell line, commonly HEK 293. One or more plasmids, generally referred to as packaging plasmids, encode the virion proteins, such as the capsid and the reverse transcriptase, while another plasmid contains the endonuclease sequence to be delivered by the vector. The plasmid carrying the endonuclease is transcribed to produce a singlestranded RNA viral genome marked by the presence of the Ψ (psi) sequence, which is used to package the genome into the virion. For safety reasons lentiviral vectors should not carry the genes required for their replication, and/or such genes should contain insert sequences so that the virus cannot replicate inside a host cell. [Kalpana, "Retroviral Vectors for Liver-directed Gene Therapy," Seminar in Liver Disease, 19: 27-37 (1999); Amado, et al., "Lentiviral Vectors—the Promise of Gene Therapy Within Reach?" Science, 285:674-76 (1999)]. Targeting efficient restriction endonuclease delivery vehicles to the desired cell types with specificity greatly enhances the therapeutic potential of the endonuclease and alleviates concerns of off-target effects in

vivo. For example, herpes simplex viruses (HSVs, such as HSV-1 and HSV-2) target
PATENT 19698

- 12 -

neurons, and hepatitis viruses target liver cells. Vectors can be more specifically targeted by being adapted to bind to a specific target cell protein on a predetermined cell type in order to specifically deliver such vectors to a cell in need thereof. Other viral vectors known to those of skill in the art, such as vectors derived from HPV [Eisenberger, et al., "A Human Papillomavirus (HPV) – based pseudoviral gene delivery system for the nonviral, Episomally Replicating Vector pEPI-1," *Gene Ther Mol Biol*, 9:371-376 (2005)], HBV, and HCMV can also be used.

Methods for specifically targeting a cell type with a viral vector are known in the art. U.S. Patent Publication No. 2007/0020238 describes the delivery of DNA to targeted cells using viral vectors as gene delivery vehicles. For targeting cancer cells, for example, viral delivery systems can be designed to target the particular cell type affected by cancer.

A preferred alternative for delivering restriction endonucleases to cells in need of treatment according to the present methods is to deliver such enzyme proteins directly to cells rather than transfecting cells with nucleic acids which must be translated in order to produce restriction endonucleases. One approach to delivering restriction endonuclease proteins to cells is to bind the nuclease to the capsid or other structural protein of a virus [as set out in Asokan et al., "Bioluminescent virion shells: new tools for quantitation of AAV vector dynamics in cells and live animals," *Gene Therapy*, 15:1618–1622 (2008)]. For example, an endonuclease as described herein can be incorporated into recombinant AAV serotypes 1, 2 and 8 capsids by fusing the endonuclease to the N-terminus of the VP2 capsid subunit, thereby forming virion shells. When endonuclease proteins are directly delivered to a host cell by a viral vector, it is preferred that no viral polynucleotides be transferred, as in the foregoing method utilizing AAV virion shells. Another approach allowing the direct transfer of proteins to cells with a viral vector is described in Pepperl-Klindworth et al., "Protein delivery by subviral particles of human cytomegalovirus," *Gene Therapy*, 10:278–284 (2003). In this method, proteins are delivered by subviral particles derived from the human cytomegalovirus (HCMV), termed dense bodies (DB), which are non-infectious. The dense bodies comprise fusion proteins made by fusing the carboxiterminus of the tegument protein (pp65) of HCMV to an endonuclease for use in the present methods. The dense bodies include such fusion
PATENT 19698

- 13 -

proteins but lack viral capsids or DNA. Delivery of such dense bodies to fibroblasts and other cell types susceptible to infection by HCMV is possible.

An alternative approach to directly delivering restriction endonuclease proteins to cells is to include peptide sequences, such as arginine-rich sequences from HIV Tat, to the endonuclease in order to promote protein penetration into cells and tissues. Several such protein transduction domain (PTD) transporter peptides have been described, for example in Siprashvili et al., "Intracellular Delivery of Functional Proteins via Decoration with Transporter Peptides," *Molecular Therapy*, 9:721–728 (2004).

In an alternative embodiment, polynucleotides encoding restriction endonucleases that can be translated within a host cell are delivered by viral vectors in the present

method. A number of viral vectors for delivering polynucleotides can be used. For example, vectors targeting neurons that can be used include those derived from HSV, including amplicon vectors, replication-defective HSV and attenuated HSV (Kriskey et al., 1998, *Gene Ther.* 5: 1517-30). Other vectors that have been developed for gene therapy uses can also be used with the methods of the invention. Such vectors include those derived from baculoviruses and alpha-viruses (Jolly, 1999, *The development of human gene therapy*, New York: Cold Spring Harbor Lab, 209-40).

A vector containing a polynucleotide encoding the restriction endonuclease of interest is preferably operably linked to a promoter which is used to drive expression of the restriction endonuclease. A promoter contains untranslated sequences that are generally located upstream (5') from the start codon of a gene (generally within about 100 to 1000 bp) and control the transcription and translation of the polynucleotide sequence to which they are operably linked. Promoters can be inducible or constitutive. Inducible promoters initiate increased levels of transcription from DNA under their control in response to some change in culture conditions, such as a change in temperature. One of skill in the art will be able to select an appropriate promoter based on the specific circumstances.

Transcription can be increased by inserting an enhancer sequence into the vector. Enhancers are typically cis-acting elements of DNA, usually about 10 to 300 bp in length, that act on a promoter to increase its transcription. Many enhancer sequences are now known from mammalian genes (globin, elastase, albumin, alpha-fetoprotein, and insulin) PATENT 19698

- 14 -

and eukaryotic cell viruses (SV40 enhancer, the cytomegalovirus early promoter enhancer, the polyoma enhancer on the late side of the replication origin, and adenovirus enhancers). The enhancer can be spliced into the vector at a position 5' or 3' to the polynucleotide sequence encoding the restriction endonuclease. Expression vectors will also preferably contain sequences necessary for the termination of transcription and for stabilizing the mRNA. These sequences are often found in the 5' and, occasionally 3', untranslated regions of eukaryotic or viral DNAs or cDNAs and are well known in the art.

Other methods for transferring restriction endonucleases or polynucleotides encoding such endonucleotides include the use of lipid reagents, as described in Example 2 below, or liposomes. Liposomes are microscopic vesicles that consist of one or more lipid bilayers surrounding aqueous compartments (Bakker-Woudenberg et al., 1993, *Eur. J. Clin. Microbiol. Infect. Dis.* 12 (Suppl. 1): S61 (1993); Kim, 1993, *Drugs* 46: 618). Liposomes can be unilamellar or multilamellar, and can vary in size with diameters ranging from 0.02 μm to greater than 10 μm . Liposomes can be prepared for targeting to particular cells or organs by varying their phospholipid composition or by inserting cellular receptors or ligands into the liposomes. Preferably, liposomes are delivered directly to tissues in need of treatment.

Methods of Treatment

The methods of the present invention treat a medical condition which involves the presence of an undesired polynucleotide in a predetermined cell type. Such medical conditions include cancer and viral infections.

Prior attempts to administer exogenously-derived restriction endonucleases to a

subject in order to treat a medical condition have not been successful. With respect to the treatment of RNA virus infections, such as HIV infections, exogenous restriction endonucleases will have no effect on circulating viruses, since restriction endonucleases act on DNA and not RNA. For this reason, the treatments of the present invention contemplate the delivery of restriction endonucleases to cells so that such endonucleases can act on DNA within infected cells, such as proviral DNA.

PATENT 19698

- 15 -

In the case of a viral infection with, for example, a virus such as HIV, which uses reverse transcriptase to transcribe its RNA genome into DNA followed by integration of the viral DNA into the host DNA, the undesired viral DNA can be excised from the host DNA using restriction endonucleases which recognize and cleave the viral DNA from the host DNA. HIV begins its life cycle when it binds to a CD4 receptor and one of two coreceptors on the surface of a CD4

+ T-lymphocyte. The virus then fuses with the host cell. After fusion, the virus releases RNA, its genetic material, into the host cell. An HIV enzyme called reverse transcriptase then converts the single-stranded HIV RNA to double-stranded HIV DNA. Following this, HIV DNA enters the host cell's nucleus, where an HIV enzyme called integrase integrates the HIV DNA into the host cell's own DNA. The integrated HIV DNA is called a provirus. To actively produce the virus, certain cellular transcription factors need to be present, the most important of which is NF- κ B (NF kappa B), which is upregulated when T-cells become activated. When the host cell receives such an activation signal, the provirus uses a host enzyme called RNA polymerase to create copies of the HIV genomic material, as well as shorter strands of messenger RNA (mRNA) which are used as a blueprint to make long chains of HIV proteins. Such proteins are then assembled with copies of HIV's RNA genetic material to produce new virus particles.

Since the HIV virus can integrate into host DNA and exist as a provirus, the only way to eradicate the virus from a cell infected in this way is to remove the proviral DNA from the infected cell. The present method accomplishes this through the administration of a restriction endonuclease to such a cell which is adapted to excise the proviral DNA. The viral DNA to be targeted includes DNA encoding conserved protein domains essential for viral production. In the case of DNA, reverse transcriptase does not have an editing function like that of human polymerases, and therefore one round of DNA synthesis results in as many as ten mutations in the HIV genome. This accounts for the great genetic and antigenic variation of HIV, and the constant emergence of new HIV strains. However, some regions of the HIV genome that encode protein domains essential for viral replication and virion production are conserved. Such conserved regions are therefore preferably targeted by the restriction endonucleases used in the present method.

PATENT 19698

- 16 -

Preferably, the endonucleases used in the present methods excise the entire proviral sequence, either by cutting the proviral sequence at its respective ends, or less preferably by cutting a host sequence on either side of the proviral sequence. In an

alternative embodiment, less than the entire proviral sequence can be excised, as long as the portion of the proviral sequence that is cut results in the virus being unable to replicate, and preferably also reduces or eliminates harm to the cell caused by viral production.

A wide variety of other viral infections, including infections caused by viruses with genomes of double-stranded DNA during at least part of their life-cycle, can be treated with the restriction endonucleases of the present invention. Notable among the double stranded DNA viruses that infect man and cause health problems are the Hepadnaviridae, for instance, hepatitis B virus; the Papovaviridae, including human papillomaviruses (HPV) 1-48, some of which are associated with the development of carcinomas; the Adenoviridae; and the Herpesviridae, including, for instance, herpes simplex viruses 1 and 2, cytomegalovirus and Epstein-Barr virus. Many of these viruses are characterized by prolonged persistence in the body in a latent form, and recurrent clinical disease which can occur throughout life. Among the viruses whose genomes are double-stranded DNA during only part of their life-cycles are the parvoviruses and the retroviruses. Notable among the retroviruses of the latter class is HIV.

Any type or stage of cancer can also be treated with the restriction endonuclease of the present invention. For example, lung cancer, colon cancer, breast cancer, testicular cancer, stomach cancer, pancreatic cancer, ovarian cancer, liver cancer, bladder cancer, colorectal cancer, prostate cancer, and hematopoietic cancers such as leukemia can be treated with the restriction endonuclease of the present invention. Following the identification of a nucleotide sequence of the cancer cell that can be cleaved in order to treat the cancer, such as an overexpressed growth factor, an appropriate restriction endonuclease capable of cleaving the nucleotide sequence can be identified. A nucleotide sequence coding for the restriction endonuclease, under the control of an appropriate promoter, is prepared, and this nucleotide sequence is packaged in a vector targeting the particular cancer cell. The vector is then administered to a subject in need

PATENT 19698

- 17 -

of treatment. Alternatively, restriction endonucleases can be directly delivered to cancer cells, such as with a viral vector, as described above.

Intracellular bacteria, such as mycobacterium tuberculosis and mycobacterium leprae can also be treated with the present method. Such bacteria invade and replicate within the cells of a subject. Restriction endonucleases directed against bacterial DNA can be administered to infected cells order to treat such bacteria. In this embodiment, the restriction endonucleases that are delivered are adapted to cut bacterial DNA sequences carried by such bacteria.

In addition, certain genetic disorders can be treated according to the present methods. Preferably, the genetic disorders treated by the present methods are single-gene disorders, caused by one or more mutations occurring in the DNA sequence of one gene. The types of genetic disorders treatable by the present methods are generally those in which a defective protein or other product of a mutant gene causes harm to a subject, such that the cleaving or excision of the mutant gene reduces or eliminates the harmful gene product. For example, in individuals with alpha-1 antitrypsin deficiency, the presence of a mutation in the alpha-1 antitrypsin sequence results in the production of an abnormal, misfolded alpha-1 antitrypsin protein which aggregates and accumulates in

liver cells. Retention of the misfolded aggregate leads to the development of cirrhosis. In the present method, the DNA producing such abnormal aggregated proteins can be cleaved in liver cells by the targeted delivery of an appropriate restriction endonuclease (or the DNA coding for such an endonuclease) to liver cells. For example, a hepatitis B virus (HBV)-based vector [as taught in Untergasser, U., "Hepatitis B Virus-Based Vectors Allow the Elimination of Viral Gene Expression and the Insertion of Foreign Promoters," Human Gene Therapy, 15: 203-210 (2004)] can be used to deliver an appropriate restriction endonuclease to liver cells in order to treat the cirrhosis associated with alpha-1 antitrypsin deficiency. In this embodiment the restriction endonuclease targets the SERPINA1 gene sequence, and preferably only SERPINA1 gene sequences containing a deleterious mutation.

The present methods can similarly treat other genetic or acquired medical conditions involving the accumulation of aberrant proteins in cells, such as Alzheimer's disease, including early-onset (genetic) Alzheimer's disease (amyloid precursor protein PATENT 19698

- 18 -

and other proteins), Parkinson's disease (torsinA and other proteins), Huntington's disease (TATA-binding protein and other proteins), amyotrophic lateral sclerosis, transmissible spongiform encephalopathies (prion protein), inclusion body myopathy, and the systemic amyloidoses. Transmissible spongiform encephalopathies (prion diseases) include classic Creutzfeldt-Jakob disease, new variant Creutzfeldt-Jakob disease, Gerstmann-Sträussler-Scheinker syndrome, and fatal familial insomnia. Such treatment is effected by delivering restriction endonucleases (or polynucleotides encoding such restriction endonucleases) to the affected cells and cutting the DNA that encodes such aberrant proteins. When the affected cells are neurons, as in Alzheimer's disease and Huntington's disease, a viral vector such as an HSV vector can be used, for example. The present methods can also be used to treat genetic disorders associated with genetic mutations when the protein product or function of the mutated gene is not known. For example, Huntington's disease is associated with mutations in the prion protein gene (HDL1), the junctophilin 3 gene (HDL2), a recessively inherited HTT gene (HDL3), and the gene encoding the TATA box-binding protein (HDL4/SCA17). Preferably, only genes with mutated sequences are targeted by the restriction endonucleases delivered according to the present methods.

Typically, for therapeutic applications, one or more restriction endonucleases or a vector encoding one or more restriction endonucleases can be combined with a pharmaceutically acceptable excipient appropriate to a planned route of administration. A variety of pharmaceutically acceptable excipients are well known, from which those that are effective for delivering the restriction endonuclease to a specific site can be selected. The Handbook of Pharmaceutical Excipients published by the American Pharmaceutical Association is one useful guide to appropriate excipients for use in the invention. A composition is said to be a "pharmaceutically acceptable excipient" if its administration can be tolerated by the recipient. Sterile phosphate-buffered saline is one example of a pharmaceutically acceptable excipient that is appropriate for intravenous administration.

For purposes of treatment, one or more restriction endonucleases or a vector encoding one or more restriction endonucleases, and a pharmaceutically acceptable

excipient are administered in a therapeutically effective amount. Such a combination is PATENT 19698

- 19 -

said to be administered in a “therapeutically effective amount” if the amount administered is physiologically significant, i.e. if its presence results in a detectable change in the physiology of the recipient. In the present context, an agent is physiologically significant if its presence results in a decrease in the severity of one or more symptoms of a medical condition caused by undesired DNA in the subject. Administration can be topical or internal, or by any other suitable avenue for introducing a therapeutic agent to a patient. Topical administration can be by application to the skin, or to the eyes, ears, or nose. Internal administration can proceed intradermally, subcutaneously, intramuscularly, intraperitoneally, intraarterially or intravenously, or by any other suitable route. It also may in some cases be advantageous to administer a composition of the invention by oral ingestion, by respiration, rectally, or vaginally. For a brief review of pharmaceutical dosage forms and their use, see *Pharmaceutical Dosage Forms and Their Use* (1985, Hans Huber Publishers, Berne, Switzerland).

Examples

Example 1: Delivery of Restriction Endonucleases: AAV Vector

The AAV capsid is comprised of three viral protein subunits, Vp1, Vp2 and Vp3. The N-terminus of Vp2 has been found to tolerate fusion with large proteins such as GFP (~30kDa), thereby allowing incorporation and surface display of non-endogenous viral proteins on the AAV onto the N-terminus of the Vp2 protein derived from the AAV2 capsid sequence.

To create a Vp2 protein displaying a restriction endonuclease, the polynucleotide sequence of such an endonuclease is first inserted into a plasmid such as pVp2AGFP (in which the GFP sequence has preferably first been removed). This plasmid is then cotransfected into HEK 293 cells with another plasmid coding for the Vp1 and Vp3 subunits, such as the pXR-ACA plasmid [the foregoing plasmids are described in Grieger et al., “Production and characterization of adeno-associated viral vectors,” *Nat. Protoc.* 1:1412–1428 (2006)]. Helper Ad genes (in plasmid pXX6-80) and packaging construct PATENT 19698

- 20 -

(in plasmid pTR-GFP) are also transfected [see, Summerford et al., “Membrane-associated heparan sulfate proteoglycan is a receptor for adeno-associated virus type 2 virions,” *J. Virol.*, 72:1438–1445 (1998)]. Virion shells containing the modified Vp2 protein as well as the Vp1 and Vp3 proteins are purified by cesium chloride density ultracentrifugation and then dialyzed against PBS in order to purify them.

Example 2: Delivery of Restriction Endonucleases: Lipid Reagent

A restriction endonuclease to be delivered to a subject is suspended in 10 mM HEPES (pH 7.0) and 150 mM NaCl and then mixed with BioPorter lipid reagent, which contains a trifluoroacetylated lipopolyamine mixed with dioleoyl phosphatidylethanolamine (available from Gene Therapy Systems, Inc., San Diego, CA). Aliquots of 0.25 μ g of endonuclease protein in 10- μ l buffer are mixed with 1 μ l of dried BioPorter lipids, and the mixture is incubated for 5 min at room temperature. The mixture is diluted in 100 μ l of serum-free medium. Aliquots of the prepared mixture are

administered to a tissue of a subject in need of treatment until a therapeutic effect is observed.

Although the present invention has been described in considerable detail with reference to certain preferred embodiments, other embodiments are possible. The steps disclosed for the present methods, for example, are not intended to be limiting nor are they intended to indicate that each step is necessarily essential to the method, but instead are exemplary steps only. Therefore, the scope of the appended claims should not be limited to the description of preferred embodiments contained in this disclosure. All references cited herein are incorporated by reference in their entirety.

PATENT 19698

- 21 -

What is claimed is:

1. A method of treating a medical condition of a subject, wherein the medical condition is characterized by the presence of an undesired DNA sequence in a predetermined cell type, comprising the steps of:
 - (a) providing a viral vector comprising a restriction endonuclease or one or more polynucleotides coding for the restriction endonuclease; and
 - (b) administering to the subject an amount of the vector capable of treating the medical condition, wherein the restriction endonuclease specifically cleaves the undesired DNA sequence.
2. The method of claim 1, wherein the undesired DNA sequence is present in or derived from a bacterium or a virus.
3. The method of claim 2, wherein the undesired DNA sequence is an HIV proviral DNA sequence.
4. The method of claim 1, wherein the viral vector is a replication defective viral vector.
5. The method of claim 1, wherein the viral vector is derived from a virus selected from the group consisting of AAV, HSV, HIV, HBV, HPV, HCMV, a baculovirus, and an alpha-virus.
6. The method of claim 1, wherein the viral vector comprises a polynucleotides coding for the restriction endonuclease and the polynucleotide is operably linked to a promoter.
7. The method of claim 1, wherein the viral vector comprises a restriction endonuclease.

PATENT 19698

- 22 -

8. The method of claim 7, wherein the restriction endonuclease is fused to a viral protein.
9. The method of claim 8, wherein the viral protein is derived from HCMV or AAV.
10. The method of claim 7, wherein the restriction endonuclease further comprises a protein transduction domain transporter peptide.
11. The method of claim 1, wherein the medical condition is selected from the group consisting of lung cancer, colon cancer, breast cancer, testicular cancer, stomach cancer, pancreatic cancer, ovarian cancer, liver cancer, bladder cancer, colorectal cancer, leukemia, and prostate cancer.
12. The method of claim 1, wherein the medical condition is a genetic disorder.

13. The method of claim 13, wherein the genetic disorder is selected from the group consisting of alpha-1 antitrypsin deficiency, Huntington's disease, and early-onset Alzheimer's disease.

14. The method of claim 1, wherein the medical condition is a viral infection caused by a virus from a family selected from the group consisting of Hepadnaviridae, Papovaviridae, Adenoviridae, and Herpesviridae.

15. The method of claim 14, wherein the medical condition is a viral infection caused by a virus selected from the group consisting of hepatitis B virus, human papillomavirus, herpes simplex virus 1, herpes simplex virus 2, cytomegalovirus, and Epstein-Barr virus.

16. The method of claim 2, wherein the bacterium is an intracellular bacterium selected from the group consisting of mycobacterium tuberculosis and mycobacterium leprae.

PATENT 19698

- 23 -

17. The method of claim 1, wherein the medical condition is cancer.

18. The method of claim 1, wherein the medical condition is selected from the group consisting of Parkinson's disease, a transmissible spongiform encephalopathy, and amyotrophic lateral sclerosis.

19. The method of claim 1, further comprising the step of combining the vector with a pharmaceutically acceptable excipient prior to administration.

PATENT 19698

- 24 -

Dear President's Council of Advisors on Science and Technology,

I am not able to participate in person. I do however respectfully request that my letter be read aloud to those in attendance at the next PCAST meeting on January 7, 2010. My letter is to inform members of PCAST about the Herpes Simplex Virus, HSV-1 (Cold Sores, Genital HSV-1 and Ocular Herpes) & HSV-2 (Genital Herpes which can become Oral Herpes.) Health care is a major issue to President Obama, many members of congress and many Americans. HSV-2 affects approximately 45 million^[1] people while HSV-1 affects 90%^[2] of people by age 50 nationwide. Here's a cure and vaccine option to show interest in. Imagine the amount of people with and without health care insurance who would be freed of getting suppressing herpes medicine monthly. This would free up hospitals greatly and allow doctors to focus on other medical issues. Herpes plays a role in the spread of HIV. Herpes can make people more susceptible to HIV infection.^{[3]&[4]} No longer shall those affected by this virus accept suppression as the norm.

90% of people infected show no signs or symptoms of being infected. After initial infection, the virus moves in the trigeminal ganglion (HSV-1) and cranial nerves near the spine (HSV-2), where it's resides as a life-long, latent virus. Though many don't experience signs or symptoms including outbreaks^[5], they're able to pass the virus to others. If you have sex, even kiss someone with no cold sores present^[6] (HSV-1 spreads at times when there are no visible symptoms due to what is known as herpes viral shedding) you have a chance of getting herpes. Condoms are not 100% effective against herpes. The herpes sore or lesion is not always located in an area covered by a condom^[7]. Many people who get tested may believe herpes testing is included, it is not. Herpes is not included in the routine Sexually Transmitted Diseases (STD) testing.^[8]

Professor David Bloom at University of Florida has created a way to cut the virus RNA to prevent reactivation. By designing special enzymes called hammerhead ribozymes, he's able to target a so-called late gene that releases its protein product relatively late after infection. With late genes, partial corruption of the genetic material is sufficient to shut down virus production, as opposed to early genes, which would require total inactivation to hinder the process.^[9] When administered by a single injection after the initial infection, the therapy provides life-long inhibition of recurring outbreaks.

Professor Bryan Cullen at Duke University is figuring out how to switch the virus from latency to its active stage. After it's active and a cold sore appears, it's treatable with the drug acyclovir, which kills replicating HSV-1. Cullen believes that a drug could be developed to block the microRNA that suppress HSV-1 into latency; once it's active, acyclovir can be used to destroy the virus permanently.^[10]

Professor David Knipe of Harvard Medical School studies the molecular and cellular biology of herpes simplex virus productive and latent infection and the mechanism of the host immune response to HSV. They've also have been studying a candidate genital herpes vaccine that they've developed, and are constructing and studying HSV recombinants as vaccine vectors for AIDS, SARS, West Nile and anthrax vaccines.^[11]

Let's focus on a cure and vaccine. There's a vaccine for Human papilloma virus (HPV) called Gardasil^[12]. Let's do the same for the Herpes Simplex Virus. Thank you President Obama, all members of PCAST and all those in attendance for listening. I hope this is a prelude to an informational research mission by PCAST on Herpes Simplex Virus cures and vaccines currently being researched.

Your consideration to have my letter read is greatly appreciated.

Sincerely,

Mark Christensen

E-mail: mcsd619@gmail.com

References

Ref: [1] Genital Herpes - CDC Fact Sheet (How common is genital herpes?)

<http://www.cdc.gov/std/herpes/STDFact-herpes.htm#common>

Ref: [2] How common is oral herpes?

http://www.ashastd.org/herpes/herpes_learn_oralherpes.cfm#2

Ref: [3] Genital Herpes - CDC Fact Sheet (What are the complications of genital herpes?)

<http://www.cdc.gov/std/herpes/STDFact-herpes.htm#complications>

Ref: [4] Scientists Learn Why Even Treated Genital Herpes Sores Boost the Risk of HIV Infection

<http://www3.niaid.nih.gov/news/newsreleases/2009/herpesHIV.htm>

Ref: [5] How common are cold sores?

http://www.herpes-coldsores.com/cold_sores.htm#how_common_are_cold_sores

Ref: [6] How is the cold sore virus spread?

http://www.herpes-coldsores.com/cold_sores.htm#How_is_the_virus_spread

Ref: [7] Steps to greatly reduce the risk of infection

http://www.globalherbalsupplies.com/herpes/prevention.html#steps_to_reduce_risk

Ref: [8] Herpes is NOT included in routine STD screening.

<http://centralcalihfriends.org/?ShowPage=1>

Ref: [9] University of Florida - Potential new herpes therapy studied

<http://news.ufl.edu/2009/02/03/herpes-2/>

Ref: [10] Duke University - A Cure for Cold Sores? Times Article

<http://www.time.com/time/health/article/0,8599,1819739,00.html>

Ref: [11] Harvard Medical School - Knipe Lab

<http://knipelab.med.harvard.edu/default.html>

Ref: [12] FDA Approves New Indication for Gardasil to Prevent Genital Warts in Men and Boys

<http://www.fda.gov/NewsEvents/Newsroom/PressAnnouncements/ucm187003.htm>

“ The auto: driving sector di every commercial activity”

A 2 –

Stroke engine high compression with or without turbosupercharger.

In 1957, I was

hired by a driving school for dispatching car practises. Since I was 16 , I have been taughing electromechanic in courses for driving license . After 35 years of attempts, in 1994 I finally understood how a high compression 2- stroke engine works using a photocopier and mechanical representations in sequential movements in sync.

Car

manufactures I contacted wanted to have the engine's diagrams without giving me any guarantee. This engine , its structure and its functionality, it has nothing , to do with the Otto cycle and Diesel one. For me it will never be patented because of the lack of security , privacy protection and various.

If the 2_ stroke engine was built and marketed I ask only one award agreed, Where is the deception on my part?

The journalist

and writer B.P , collaborator of the newofaper “Il Giornale” saind: “ The 2-stroke cycle is known to be very interesting and really unbeatable in terms of specific power (the single cylinder 125 cc motorcycle championship come easily to 50 Hp)but the problems of pollution that creates a 2- stroke engines, led to its departure from the scene because these problems are insurmountable.

In this case thee is evidence such as Orntal, the Australian company that patented a system for fuel injection 2- stroke engine. There have been many attemps, Fiat and Ford have triend it . I myself have tried both on a Ford fiesta that on a Fiat UNO with a tree-cylinder 2-stroke Orbital and I also tried a six cylinder with external washing, mounted on BMW 3 series instead of 2500 cc. Unlike the technical failure of the 2-stroke engine, the injection lighting propeller spontaneous or commanded, there is no overlapping of the phases that the piston completes for opening and to close the lights in the cycle loop of the actual motors. The air to come introduced through to pressure a technical device, without loss volumetrical of the air, for the simple motive that there is an only light, that of unloading. Besides, to motive for the tall compression the position of the fuel-combustive one, the combustion is total and you/he/she is completed to 3/4 some run of the piston to the PMI (stings dead inferior) where it opens the light of unloading. Relationship of compression, 8-13:1 to burst; 20-30:1 spontaneous lighting. Here included, you confind a scheme of the motor to 2 Times and industrial answers.

Yours Sincerely

Capriotti Franco

Capriotti Franco; 29,

Via Galié; 63100 Ascoli Piceno; Italy

Dear Sir

Hi...

I want to cooperate with you Subject : marketing or investing invention (the axial internal combustion engine) in Your country . It is new internal combustion Engine in all details, It is economic very much, and this mean:

It is environment solution: less oil=less burning=less co2

(3stroke:2+1) It is use the normal fuel (petrol, diesel, gas) It is for cars, trucks , train, chains, ships, ...etc. the subject is very important.

I am ready to more information

Documents:

1. patent 5227 (Syria)
2. PCT 7 (Syria)
3. PCT (WIPO-Suisse) PCT/SY2004/000007
4. PCT (Austria) PCT/SY2004/000007
5. EPO (Netherlands) 04800462.6-1263

More information with Attachment.

With best thanks.

Muhammad Altibani Syria - Hama - Aldahrieh - Jesr Alhadid

Mobile: 00963 956 435923 E mail: qasioon@gmail.com

<http://www.afkaaar.com/html/modules.php?name=News&file=article&sid=62>

http://www.mawhapon.net/ver_ar/news.php?news_id=4210

see attached

Thank you

Robert Handy

2643 Stony Point Rd #10

Santa Rosa Ca 95407

ph 707-568-6126

email handysnt@aol.com

April 17, 2009

RUKEYSER NOTES

Louis Rukeyser Mentally Retarded in Board and Care home in Northern California. I heard the radio station KCBS San Francisco over the brain wave every night since October 25, 2007. The brain wave

system. Talked to me 24 hours a day till I got sleeping Pills. Lost 4 jobs since he started on October 25, 1996. Homeless 2 different times. In jail 2 times. Stinging and burning me with forms while I worked at Crosscheck. Forms were on me prior to him speaking to me in October of 1996 for a month. Taking medication since October of 1997. came up with truth-teller June 8th 1998. Suicide attempt in 2001 called twice for a gun to Warren Ness in the phone book. I have notes on the calendar On March 8th of 1997 I told him a million dollar a day penalty for every day it stays on. Capped it at 10 million on December 31st 1997. Said he was going to kill me with the system on November 5, 2007. On December 1 2007 told Louis Rukeyser I would not press charges because he is mentally retarded and his grandfather told him he could do it. As of July 20th 2008 Louis Rukeyser stated that he would kill me by not letting me sleep. February 22 stated that he knew what he was doing. August 24, 2007 Louis stated that there were 2 people that committed suicide. September 3rd 2007 Louis stated that a white female committed suicide by taking pills. Also one black male committed suicide by gun shot wound. On September 6th Louis stated that additional 3 people all black males committed suicide by gun shot wound. He reached these people by stating on the brain wave system any black person who does drugs. He reached me because his grandfather had my name. I think his grandfather sent me dreams or videos when I was 12 years old. October 12, 2008 8:04AM "I remember all the murder victims" 8:07AM I killed 3 people between the cities of Vallejo and Pasadena. 12:13PM Three attempted murders against me He said "TRUE" October 21, 2008 He said "Trying to kill me. October 27, 2008 10:14AM "Talked about the murders because there was nothing else to talk about". The videos were about lions or tigers. The videos or dreams were in back to back nights. October 31, 2007 Louis promised me death by sending me pictures. November 5th 2007 Louis promised me he would murder me. November 7, 2008 5:27PM I know I killed people. 5:41 PM Vallejo and Pasadena only 3 murders. November 13th 2007 Louis started sending me videos of a racist nature one was about black people chasing some one around. The video gave the feeling that you were carrying something and you had something in your mouth. The second one was black people running from a disease. The video is how he ran people down by not letting them sleep. He said it took 6 months and the last 35 days on average the victims were begging him to stop. November 20th 2007 Louis stated he knew what he was doing with the suicide murders. November 27, 2007 Louis stated he knew the names of the murder victims and their cities. December 6th Louis stated his grandfather taught him to duplicate voices and operate the system.

April 30th 2008 Louis's brain confirmed he admitted killing those five people 427 times since September of 2007. On May 1st Louis's brain confirmed that he knew what he was doing with the murders 35 times. July 9th Louis's brain told me on average the murder victims begged him to stop for 35 days before they killed themselves. On July 20th 2008 Louis says he is setting me up for murder. July 26th 2008 his brain said he hooked up to 62 people or maybe as many as 102 people of which 1 white female was killed and 4 black males were killed. On July 29th 2008

lewis used situation described to nail black people who used drugs. On July 30th Louis Rukeyser said being retarded did not matter in why he killed those 5 people. On August 4th Louis tried to make a video off the TV to keep me from sleeping. June 14, 2005 stopped the duplicated voices. June 17, 2006 got his name Louis Rukeyser. In Oakcrest mental hospital 3 different times. That's in Santa Rosa. April 15th 2005 found he was mentally retarded by using a Internet September 15, 1998 thru October 1, 1998 Louis stung with forms. Forms are magnetic human images. They look like silver clouds in a human shape.

Louis Rukeyser hooked up to 103 people including myself. 75 white people of which 15 were white women and Virginia Ingram a white female is the only white person dead. He hooked up to 5 black males including myself and 4 of us are dead, gunshot wounds. The other 28 people he talked to their brains on the right side and ran the videos. I stopped him from talking in duplicated voices of June 14, 2005. I got his name by truth telling his head on June 17, 2006. August 4, 2008 Louis tried to make a video off the TV. He played it and I stopped with my brain waves. On August 6th 2008 Louis stated that the people who committed suicide wrote their note 2 days ahead of time. On August 17th Louis stated he killed because the men would not get their girlfriends to show them their private parts. He killed women for the same reason. On August 18th 2008 he stated that people have to die. August 21st 2008 Louis said he never asked questions on the right side of the brains he just wanted to know what they were going to do next. He also said he remembered all the murders. He said his grandfather told him not to kill people. He got the brain wave system on Christmas day 1975. The 26th of August 2008 Louis said he talk to people until they died. On the 28th of August 2008 I read to Louis Rukeyser out of the Press Democrat newspaper that mentally retarded people can't be executed for murder. August 31st 2008 Louis said that four black people are dead. September 3rd 2008 at 7:54 am Louis repeated 5 people are dead. One by pills and 4 by gunshot wounds. Also he stated that the troops don't need this system so "Fuck the troops." September 11th 2008 "Don't doubt I killed people." 8:25 AM There was blood every where. September 12th 2008 I raised the penalty for staying on me to 20 million dollars a day. September 23rd 2008 he said "Fuck the troops." September 24th 2:29 pm "I'm not that mentally retarded." September 25 2008 4:57 AM "videos are for attempted murder" September 29 2008 12:16 PM "I like killing people." 6:42 PM "I killed some people." October 9th 2008 seen private parts of women but did not know it. October 12 8:04 am "I remember all the murder victims." October 17 I said 3 attempted murders against me. He said "True." October 21st 2008 9:18am "Trying to kill me." October 27th 2008 10:14 am Talks about the murders because there is nothing else to talk about. October 29th 2008 2:15 pm "Says he killed people."

November 7 2008 "I know I killed people." November 16, 2008 "I am still trying to kill you." December 9, 2008 "I killed because people would -not know it." December 31, 2008 I Robert Handy stopped talking.

January 5, 2009 7PM "I knew what I was doing when I killed those people." January 6, 2009 11:27 AM I know the names of the people that I killed.

February 1, 2009 4:17 PM "I know I am playing with peoples lives" 6:08 PM "Tapes mean I am trying to kill people." February 5, 2009 7:08PM "When I run the tapes I'M trying to kill people." February 8, 2009 11:30 AM "Robert Knows about the murders."

March 17, 2009 Ran videos with colorful leaves falling I fought it off with my brain. March 19, 2009 5:21PM "I don't care how many people get killed." March 23, 2009 12:44 PM "I tried to kill all I hooked up to." March 30, 2009 4:30PM "I knew it was a crime when I started."

April 1, 2009 8:17 AM "I'm trying to kill you." 1:33PM "I killed the first person in 1979." April 9, 2009 10:21 AM "I'm going to kill you too." April 23, 2009 9:40AM "I understand the charges of attempted murder and torture." 12:05PM "I'm not a killer I just killed 5 people."

May 10, 2009 12:44PM "I wish I had not killed those people."

July 19, 2009 I hear the radio station KSR 1350 AM out of Santa Rosa last night.

August 23, 2009 12:50 PM "I made them suffer. I enjoyed it." August 26, 2009 11:50 AM "I admit to it. I know I did it." 2:30PM "I enjoyed it."

September 4, 2009 2:59PM "I killed them for no reason. Why did I have to do that?"

November 7, 2009 My brain says he admitted 36 times that he has killed people since August of 2007. 4:38PM

December 15, 2009 Louis Rukeyser put a white spot in my eyes to keep me from sleeping last night.

December 29, 2009 Last night Louis Rukeyser put yellow pages in my eyes to keep from sleeping.

March 3, 2010

The Honorable John Holdren
Co-Chair, President's Council of
Advisors on Science and Technology
Director, Office of Science and
Technology Policy
White House
1600 Pennsylvania Avenue, NW
Washington, DC 20500
The Honorable Eric Lander
Co-Chair, President's Council of
Advisors on Science and Technology
President and Director,
Broad Institute
7 Cambridge Center
Cambridge, MA 02142

The Honorable Harold Varmus
Co-Chair, President's Council of Advisors on Science and Technology
President, Memorial Sloan-Kettering Cancer Center
1275 York Avenue New York, NY 10065

Dear Drs. Holdren, Lander, and Varmus:

The Science, Technology, Engineering, and Mathematics (STEM) Education Coalition is pleased to provide comment to the President's Council of Advisors on Science and Technology (PCAST) as you move forward with a report on a wide range of policies related to STEM education.

As our country deals with the current economic downturn and prepares for a robust recovery, it is absolutely essential that we pay close attention to the role STEM education plays in ensuring the competitiveness of our workforce. To bolster our nation's STEM education system, we must employ a robust range of policies, solutions, and partnerships.

The STEM Education Coalition has actively promoted positive STEM education reform before Congress and the Executive Branch, and we have been engaged in many of the major legislative debates of the last several years, including the *Higher Education Opportunity Act*, the *America COMPETES Act*, efforts to reauthorize the *Elementary and Secondary Education Act*, and the annual appropriations process.

As you proceed with your work, we respectfully request the following key principles be given strong consideration in your report to President Obama.

1. The Federal Government Must Provide Strong and Sustained Support for Key STEM Education Priorities

We strongly urge that PCAST recommends increased funding for NSF's EHR Directorate and the Math and Science Partnership Program at the U.S. Department of Education.

We urge the PCAST to carefully review STEM-focused education initiatives authorized in the Higher Education Act and America Competes Act as a part of your study of potential federal STEM education initiatives.

The PCAST report should include strong language that clarifies the roles and responsibilities of federal R&D mission agencies in STEM Education and calls for the coordination of STEM education programs across the federal agencies.

The PCAST report should also address the portion of the federal STEM portfolio dedicated to K-12 programs

2. Science, Technology, Engineering, and Mathematics Education Must Be Clearly Defined

PCAST should include a clear definition of STEM education and define what STEM education means in the context of preparing the next generation to be career or college ready. Federal STEM education initiatives must include technology and engineering educators and programs. Computer science education should also be a major component within the STEM conversation.

3. Stakeholders Must Work Toward the Alignment of STEM Education

To ensure that all students have an opportunity to learn 21st-century skills, we encourage PCAST to support the development and implementation of policies that will encourage a vertical alignment of P–20 STEM education that includes these stakeholders: Higher Education/Undergraduate, Community Colleges/CTE, After-School Programs, and Informal Education.

4. STEM Teaching and Learning Must Be Improved

A systemic approach to improving teaching and learning in the STEM fields must focus on Standards, Assessments, and Accountability; Teacher Preparation and Professional Development; Increasing Diversity in the STEM Pipeline; Linking Research to Classroom Practice; Increasing Classroom Resources; and Recognizing the Importance of Informal Learning.

More information on these key principles can be found in the white paper below. We appreciate the strong commitment of the Administration to addressing the challenges facing STEM education and our nation's competitiveness in the global economy and hope that the recommendations offered here will help inform your deliberations on this vitally important subject.

For any additional information on STEM education please do not hesitate to contact Coalition Co Chairs, James Brown (American Chemical Society) at 202-872-6229 or Jodi Peterson (National Science Teachers Association) at 703-312-9214.

Sincerely,
Action Works
Aerospace Industries Association
Alabama Mathematics, Science, and Technology Education Coalition (AMSTEC)
Altshuller Institute for TRIZ Studies
American Association of Colleges for Teacher Education
American Association of Physicists in Medicine
American Association of Physics Teachers
American Association of University Women (AAUW)
American Astronomical Society
American Chemical Society
American Helicopter Museum & Education Center
American Institute of Aeronautics and Astronautics
American Institute of Biological Sciences
American Museum of Natural History
American Society for Engineering Education
American Society for Microbiology
American Society of Agronomy
American Society of Civil Engineers
American Society of Heating, Refrigerating and Air-Conditioning Engineers, Inc.
American Statistical Association
ASME Center for Public Awareness
Association for Computing Machinery
Association of Public and Land-grant Universities – APLU
Association of Science-Technology Centers
ASTRA
Baltimore Washington Corridor Chamber
Battelle
Biophysical Society
BSCS (Biological Sciences Curriculum Study)
Carnegie Corporation of New York
Center for Excellence in Education (CEE)
Center for Minority Achievement in Science and Technology (CMAST)
Computer Science Teachers Association
Computing Research Association
Council on Undergraduate Research
Crop Science Society of America
DEPCO, LLC
Destination ImagiNation, Inc.
EAST Initiative
Education Development Center, Inc.
Engineers Without Borders-USA
Entertainment Industries Council, Inc.
Exploratorium

Falcon School District 49 PreK-12 STEM Educational Initiative, Colorado Springs, CO
Funutation Tekademy LLC
Hands On Science Partnership
Illinois Mathematics and Science Academy
Institute for Advanced Study
International Technology and Engineering Education Association (ITEEA)
Knowles Science Teaching Foundation
LearnOnLine, Inc
Museum of Science and Industry, Chicago
Museum of Science, Boston
NASA STEM School Administrators Association
National Alliance for Partnerships in Equity
National Alliance for Partnerships in Equity Education Foundation
National Center for Science Education
National Center for Technological Literacy
National Council for Advanced Manufacturing
National Council of Teachers of Mathematics
National Girls Collaborative Project
National Science Teachers Association
National Society of Professional Engineers
National Youth Science Foundation
NDIA
Ohio Mathematics and Science Coalition
Pathways into Science
PBS
Project Exploration
Project Lead The Way
PTC
PTC-MIT Consortium
Real World Design Challenge
REVOLUTIONARY DESIGNS
SAE International
Science Teachers Association of New York State
Society for the Advancement of Chicanos/Hispanics and Native Americans in Science (SACNAS)
Society of Women Engineers (SWE)
Soil Science Society of America
South Carolina's Coalition for Mathematics and Science
SPIE, the International Society for Optics and Photonics
STEMES
Technology Student Association
The Society of Naval Architects and Marine Engineers
Triangle Coalition
Vernier Software & Technology
Water Environment Federation

Science Technology, Engineering and Mathematics (STEM) Education Coalition
Key Recommendations to President's Council of Advisors on Science and Technology
March 3, 2010

The Federal Government Must Provide Strong and Sustained Support for Key STEM Education Priorities

For many educators in the field the federal government provides a vital source of support for STEM education programs. To promote meaningful education reform, the federal government must provide strong and sustained resources for STEM-focused education programs that provide direct assistance to educators and educational institutions.

We must increase the resource commitment to the National Science Foundation Education and Human Resources (EHR) Directorate. NSF education programs are designed to support and improve U.S. STEM education at all levels and in all settings—both formal and informal—and are unique in their capacity to move promising ideas from research to practice, to develop new and improved materials and assessments, to explore new uses of technology to enhance K–12 instruction, and to create better teacher training techniques. *We strongly urge that PCAST recommends increased funding for NSF's EHR Directorate going forward.*

We also strongly support the Mathematics and Science Partnership (MSP) program at the Department of Education, authorized via Title II, Part B of the No Child Left Behind Act. This program is the only dedicated source of funding for STEM education at the Department of Education and should be fully funded in future Administration budgets.

Beyond these two key federal STEM education funding sources, our Coalition has also supported a range of new STEM-focused education initiatives as authorized by the *Higher Education Act* and the *America COMPETES Act*, including the Math Now program, the Laboratory Science Pilot program, and integrated teacher education programs based upon the U-TEACH, Cal-TEACH and PhysTEC models. *We urge the PCAST to carefully review these two pieces of bipartisan and broadly supported legislation as a part of your study of potential federal STEM education initiatives.*

Finally, to ensure that federal STEM education programs are an efficient use of federal funds, the *PCAST report should include strong language that clarifies the roles and responsibilities of federal R&D mission agencies in STEM Education and calls for the coordination of STEM education programs across the federal agencies.*

Federal R&D mission agencies, particularly those with federal research facilities, have a unique role to play in STEM Education. They can provide students and educators with hands-on research and experimental learning opportunities with world-class scientists. It is critical that all federal agencies with STEM initiatives work together to ensure that the best practices to improve student learning are shared and widely replicated and their programs are properly implemented and evaluated.

The PCAST report should also address the portion of the federal STEM portfolio dedicated to K-12 programs. As reported at the October meeting, the Federal agencies reported that a very small portion of their STEM funds actually went to K-12 programs.

Science, Technology, Engineering, and Mathematics Education Must Be Clearly Defined

PCAST should include a clear definition of STEM education and define what STEM education means in the context of preparing the next generation to be career or college ready.

Federal STEM education initiatives must include technology and engineering educators and programs. The term *engineering and technology education* means a curriculum and instruction that (a) uses technology as a way of teaching innovation using an engineering design process and context; (b) develops an understanding of technology through design skills and the use of materials, tools, processes, and resources; and (c) through the application of engineering and design principles and concepts, develops proficiency in abstract ideas and in problem-solving techniques.

Studies have shown that technology and engineering programs often provide the bridge between math and science and the much needed relevance to learning that will encourage students to pursue not only studies in the STEM fields but also STEM careers. The creative and problem-solving skills that are used in technology and engineering settings are critical to the development of the 21st-century workforce.

Computer science education should also be a major component within the STEM conversation.

Computing drives innovation, economic growth, and societal change. There is a tremendous need to expose students to computer science, yet there are numerous challenges, particularly in K–12 education. PCAST can take the lead in defining the need for an educational system that values computer science as a discipline.

Stakeholders Must Work Toward the Alignment of STEM Education

In the October 30, 2007, National Action Plan for Addressing the Critical Needs of the U.S. Science, Technology, Engineering, and Mathematics Education System, the National Science Board (NSB) points out: “*The nation faces two central challenges to constructing a strong coordinated STEM education system: Ensuring coherence in STEM learning and ensuring an adequate supply of well prepared and highly effective STEM teachers.*”

The NSB recommends that we must promote vertical alignment of STEM education across the grade levels by:

Improving the linkages between high school and higher education and the workforce

Creating or strengthening STEM education focused P–16 or P–20 councils in each state
Encouraging alignment of STEM content throughout the P–12 education system

To ensure that all students have an opportunity to learn 21st-century skills, we encourage PCAST to support the development and implementation of policies that will encourage a vertical alignment of P–20 STEM education that includes these stakeholders: Higher Education/Undergraduate, Community Colleges/CTE, After-School Programs, and Informal Education.

STEM Teaching and Learning Must Be Improved

A systemic approach to improving teaching and learning in the STEM fields must focus on Standards, Assessments, and Accountability; Teacher Preparation and Professional Development; Increasing Diversity in the STEM Pipeline; Linking Research to Classroom Practice; Increasing Classroom Resources; and Recognizing the Importance of Informal Learning.

Standards, Assessments, and Accountability

The 2009 Carnegie Corporation of New York-Institute for Advanced Study report “The Opportunity Equation, Transforming Mathematics and Science Education for Citizenship and the Global Economy” calls on the nation to “Establish common standards that are fewer, clearer, and higher and that stimulate and guide instructional improvement and galvanize the nation to pursue meaningful math and science learning for all Americans.” *PCAST should support the efforts to develop common core standards in mathematics and science that are more focused, aligned, and coordinated with assessments and teacher professional development.*

Teacher Preparation and Professional Development

Government Accounting Office report GAO-06-114, Federal STEM Education Programs notes “University officials frequently cited teacher quality as a key factor that affected domestic students’ interest in and decisions about pursuing STEM degrees and occupations . . . Researchers also noted that poor teaching at the university level was the most common complaint among students who left as well as those who remained in STEM fields. Students reported faculty do not like to teach, do not value teaching as a professional activity, and therefore lack any incentive to learn to teach effectively.”

PCAST must address teacher preparation in the STEM fields. We must change university culture in fundamental ways to bridge the cultural divide between the schools of arts and science and schools of education and their efforts to encourage and retain more students in STEM fields. More collaboration between these communities would lead to stronger teacher preparation programs in science, mathematics, and technology and would vastly improve the “system” of education. Experiential, hands-on learning must also be extended to higher education undergraduate programs, including programs at community colleges.

Long-term, coherent, reform-based professional development for STEM teachers is also essential. Ongoing quality professional development must increase and deepen content knowledge, promote a variety of pedagogical approaches, and develop questioning strategies, which will advance higher-order thinking of students. While it is commonplace for most businesses to invest funding in staff training, very few district dollars are budgeted for teacher professional development. Increased federal funding for professional development will help state and local school districts provide STEM-specific professional development to both preservice and inservice teachers. Informal learning institutions can play a key role in both teacher professional development and preparation.

Increasing Diversity in the STEM Pipeline

According to The American Council on Education report “Increasing the Success of Minority Students in Science and Technology” “The nation's changing demographics and continued need to remain globally competitive make it clear that colleges and universities must increase the number of Hispanics and African Americans earning degrees in science, technology, engineering, and math (the STEM fields). Thirty-nine percent of people under age 18 in the United States are persons of color and this percentage will continue to increase placing young people of color at the vanguard of the next generation. It is upon this generation that the nation places its hopes for continued economic competitiveness in the Information Age.”

Similarly, women are also underrepresented in the STEM workforce. The Commission on Professionals in Science and Technology's 2007 report, "Professional Women and Minorities," noted that women make up 25% of the labor force in the STEM fields. However, that proportion varies widely, with fewer women in occupations that require a high level of skill in math, such as engineering. Women comprise no more than 15% of any engineering subdiscipline (i.e., mechanical, electrical, civil, industrial, etc.) and only 9.5% of engineering managers.

NAEP scores for grade four and eight math and science students tell us that many of these challenges to increase diversity in the STEM pipeline begin at the K–12 level. The average NAEP scores for students in urban areas are lower than the national average in both mathematics and science. We simply must find effective ways to reach these young people to ensure a high-quality STEM workforce in future years.

Linking Research to Classroom Practice

Critical research in STEM education must be implemented in our classrooms nationwide and used in a manner leading to increased student achievement in the STEM areas. Programs like the National Science Digital Library (NSDL) provide an outstanding resource and archive of peer-reviewed and edited on-line science education resources for K-20. Yet linking research to everyday classroom practice is a challenge for far too many districts. The problem is twofold. First, we simply must find better ways to link the community of STEM education researchers, including those in the federal agencies, with one another and with schools. Second, we must effectively disseminate and actively implement the

vast research findings that can and will have an impact on our schools and classroom teachers. *PCAST can recommend continued investments in research on teaching and learning that will better inform development of science, mathematics and engineering curricula and pedagogical approaches and suggest methods to better link this research to classroom practice.*

Increasing Classroom Resources

Teachers and schools must have requisite materials and equipment to properly teach the STEM subjects. Although no specific research is available on STEM educators specifically, according to the QED “2006–2007 Teacher Buying Behavior Report,” on average teachers report spending a total of \$475 of their own money on classroom materials and supplies. Forty-four percent of respondents spend over \$500 on their classrooms, with 20% spending over \$1,000, and 38% of teachers report needing materials that support differentiated instruction. *PCAST can encourage comprehensive federal policy that will ensure that STEM classrooms are adequately supported.*

Recognizing the Importance of Informal Education

According to the National Research Council report “Learning Science in Informal Environments: People, Places, and Pursuits,” people do, in fact, learn science in a variety of nonschool settings. Among those are “designed spaces” like museums, science centers, zoos, aquariums, and environmental centers, which as the NRC states are “rich with real-world phenomena, these are places where people can pursue and develop science interests, engage in science inquiry, and reflect on their experiences through sense-making conversations.” *PCAST should support a strong federal investment in informal STEM learning for Americans of all ages and backgrounds.*

Dear Aneesh,

As an introduction my name is Shree Pragada. I am the Founder & CEO of ExeCue, Inc. We are a venture funded startup focusing on searching structured data. Like millions, we are avid followers of your progress with DATA.GOV and wanted to connect with you about our product www.Semantifi.com. While DATA.GOV makes data accessible, it is NOT TRULY TRANSPARENT UNTIL THEY ARE SEARCHABLE and that is our goal.

ExeCue envisions the future search is data and a large part of web data is expected to be Government Data. Recognizing this vision, Microsoft has launched Open Government Data Initiative to host the massive amounts of data on their Azure Cloud Platform. ExeCue has taken one step further to make these datasets SEARCHABLE.

ExeCue has developed a search platform to search both databases & documents so users can ask simple questions and get relevant knowledge driven results. When searching databases, ExeCue shows automatic charts & tables in real-time even from multi-terabyte databases.

Using this technology, ExeCue launched SEMANTIFI.COM as an open & free search portal where the community can build & share Search Apps. Search Apps are essentially search engines customized for specific Web Pages or Web Data.

The collection of Search Apps can provide meaningful results from millions of datasets which are currently simply hidden for leading purpose search engines.

Semantifi.com has initial Apps to search datasets covering SEC Filings, Analyst Ratings, US Economic Metrics, Government Spending, Earmarks, and CrunchBase's Venture Funding activity. To see the value for internet users, compare search queries like "Amazon, Best Buy Sales and Income" at <http://Finance.Yahoo.com>, "Cleantech companies from Boston" at <http://www.Crunchbase.com>, "Earmarks by Senator" at <http://taxpayer.net> with <http://www.Semantifi.com>.

I would very much appreciate the opportunity to discuss in further detail if you could suggest your availability for an introductory call/meeting.

Regards,

Shree Pragada

CEO, ExeCue, Inc. (C)914.433.1776

product: <http://www.semantifi.com>

blog: <http://blog.semantifi.com>

From: William Lacy BROGGCAST.com

(broggcastfriends@gmail.com)

To: Aneesh Chopra

BROGGCAST.com, has a Super-Majority of web-browser video playback support, over YouTube with only two web browsers (at only 9%) of the new HTML5-TV ready web browsers.

President Obama can have a stronger high-tech media presence using the new OGG-video format used by BROGGCAST.com

Here is the link, which shows that BROGGCAST.com, is in the Super-Majority, of web browser video playback.

<http://www.oggtv.com/communicate.html>

President Obama can have a channel on the original high-tech HTML5 video site, (which was a year ahead of YouTube with HTML5), and connect with a new level of tech users.

BROGGCAST.com is a hometown Chicago Dot-Com also, which will be a positive for the area, after the Olympic bid loss.

Supporting the ""ORIGINAL"" HTML5-TV video site, will be positive as a show of support, while not buying into Google, and Apple's powerful PR news campaigns on the web, and psychology tactics with search and fake ""popularity"" tactics on the public, which keep all of the web results in their favor.

I want the President to acknowledge a positive and constructive Dot-Com, which does not bend the rules to ""look"" popular to the web, and keep everything in their favor.

Basically an official Obama Channel on BROGGCAST.com, will show, -the Whitehouse is serious with working with new technology companies, instead of just the ones in control of the internet.

<http://www.oggtv.com/communicate.html>

thanks

William Lacy

Why do you have absolutely no support for Cold Fusion research? It is not a hoax. For proof of this, see CBS 60 Minutes segment on Cold Fusion aired April 18, 2009 entitled ""More than Junk Science"". See also Defense Intelligence Agency Defense Analysis Report DIA-08-0911-003 dated 13 November 2009 Subject "Low Energy Nuclear Reactions".

I have also posed this question to The President and The Secretary for Energy.

James H. Cook

Dear Mr./Ms.,

I am writing to You regarding information on PCAST subcommittees. Where can I find in-depth information about the PCAST subcommittees?

Regards,

Noemi Gulya

Dear Mr. President, First Lady and Officers of Science and Technonlgy,

How wonderful. Science and Technology. Children the focus for Nutrition and Exercise. Health Care also a focus. Health Insurance Companies having to let go of their choke hold.

I will send my other Lesson Plans as soon as I can. Renovating takes time. I went through some blips in relationship with Marvin. I don't know what that's about. My Career is and always has been my focus since I learnt what the word Career means.

I'm trying to make my Classroom as beautiful as I can.

Sonja

On your Science landing page you mention, "Finally, it means ensuring that all Americans have the science, technology, engineering and mathematics (STEM) education they will need to participate in modern society and to be a part of a reinvigorated American economy.

Among the benefits to be gained by this renewed support for American science and science education:

- Improved American Agricultural Productivity: Modern agronomic techniques offer solutions to the serious challenges facing farmers in the United States and around the world, including climate change, declining fresh water reserves and the need to reduce the substantial energy inputs and CO2 emissions attributable to agriculture."

But yet Food Science is not considered a STEM program. Why do you not consider Food Science a STEM program, yet mention it in the same breath? What would you like to say to all those Land Grant Universities out there that have Food Science Departments? What message do you want to send them?

Dear OSTP/PCAST and NASA Communications and Advisory Council staff,

I read, with interest, a recent online article by Dr. Alan Buis of the Jet Propulsion Laboratory: "Temperature Trackers Watch our Water World", from the February 23, 2009 Earth Observatory. I am involved in estuarine water quality monitoring for the state of Connecticut in a cooperative effort with EPA's National Estuary Program - The Long Island Sound Study. Temperature data holds a good deal of interest for us as it relates directly to the Sound's dissolved oxygen regime and living resource populations.

However, the article reiterated in my mind the need for leadership in moving the U.S. to the use of metric units of measurement. I continue to be frustrated by the fact that some of the most outstanding scientific and engineering minds in our country (and probably in the world) continue to feel the need to interpret every metric unit into its "American" equivalent - 3 meters (10 feet); degrees C (degrees F).

I emailed Dr. Buis with these comments and he responded that while CalTech, with whom JPL is linked, uses metrics, the NASA field center with whom they are also associated uses the "American" units. I am dismayed by the fact that our universities and research scientists understand the need to use metrics, but our Nation's lead scientific agencies continue to promote the American system.

It is because our nation's scientists continue to use these units, constantly "interpreting" into metric, that our schoolchildren continue to learn them. Thirty-five years ago our nation was promoting the "switch" to metric, yet my kids still learn inches, yards, pounds, ounces, Fahrenheit first, and only then learn how to "convert" to what the rest of the world uses. How is this helping our children who will strive to be our next great scientists and engineers?

I think the scientific leaders in this country need to set a better example and insist that the education system in this country follow suit. It is long overdue.

Perhaps you can find a way to rekindle a commitment to metric in this Nation's scientific agencies and throughout our educational system. I think such an effort is essential to improving our children's, and our Nation's, success with regard to mathematics and scientific achievement.

Thank you for your time and attention.

Sincerely,
Christine Olsen

Christine B. Olsen
Environmental Analyst 3
Connecticut Department of Environmental Protection Bureau of Water Protection and
Land Reuse Long Island Sound Water Quality Monitoring Program
79 Elm Street
Hartford, CT 06106-5127
(860)424-3727
christine.olsen@ct.gov